

TEST REPORT

Product: Document Camera

Model No.: IRIScan Desk 5

Trade mark: N/A

Report No.: TCT190408E903

Issued Date: Apr. 12, 2019

Issued for:

IRIS S.A

10 Rue du Bosquet, 1348 Louvain-La-Neuve, Belgique

Issued By:

Shenzhen TCT Testing Technology Co., Ltd.

**1B/F., Building 1, Yibaolai Industrial Park, Qiaotou, Fuyong, Baoan District,
Shenzhen, Guangdong, China**

TEL: +86-755-27673339

FAX: +86-755-27673332

This test report was based on TCT190307E015, Change Model No., Applicant, Applicant Address, Manufacturer, Manufacturer Address and Photographs.

Note: This report shall not be reproduced except in full, without the written approval of Shenzhen TCT Testing Technology Co., Ltd. This document may be altered or revised by Shenzhen TCT Testing Technology Co., Ltd. personnel only, and shall be noted in the revision section of the document.

The test results in the report only apply to the tested sample.

TABLE OF CONTENTS

1. Test Certification.....	3
2. Test Result Summary	4
3. EUT Description	5
4. Test Methodology	6
4.1. Decision of Final Test Mode.....	6
4.2. EUT System Operation	6
5. Setup of Equipment under Test	7
5.1. Description of Support Units	7
5.2. Configuration of System Under Test.....	7
6. Facilities and Accreditations	8
6.1. Facilities	8
6.2. Measurement Uncertainty	8
7. Emission Test.....	9
7.1. Conducted Emission at AC Mains Power Ports.....	9
7.2. Conducted Emission at Analogue/Digital Data Ports.....	13
7.3. Conducted Emission at the antenna terminals.....	15
7.4. Wanted signal and emission voltage at the RF output of equipment with incorporated or with add-on RF video modulator	17
7.5. Radiated Emission	19
7.6. Harmonic Current Emissions.....	24
7.7. Flicker and Voltage Fluctuation	25
8. Immunity Test.....	27
8.1. General Performance Criteria Description	27
8.2. Electrostatic Discharge (ESD)	28
8.3. Radio-frequency Electromagnetic Field Amplitude Modulated (RS).....	32
8.4. Electrical Fast Transient (EFT)	35
8.5. Surges	38
8.6. Radio-frequency Continuous Conducted (CS).....	40
8.7. Power-frequency Magnetic Field (PFMF).....	42
8.8. Voltage Dip & Voltage Interruptions.....	44
9. Photographs of Test Configuration	46
10. Photographs of EUT	50

1. Test Certification

Product:	Document Camera
Model No.:	IRIScan Desk 5
Applicant:	IRIS S.A
Address:	10 Rue du Bosquet, 1348 Louvain-La-Neuve, Belgique
Manufacturer:	Beijing Mysher Technology Co., Ltd.
Address:	Unit B306, Building #1, Info. Center, ZhongGuanCun Software Z-Park, HaiDian District, Beijing, China (100193)
Test Voltage:	DC 5 V (Notebook Computer Input AC 230 V \pm 10 V & AC 110 V \pm 10 V, 50/ 60 Hz)
Date of Test:	Mar. 07, 2019 ~ Mar. 19, 2019
Applicable Standards:	EN 55032: 2015 EN 61000-3-2: 2014 EN 61000-3-3: 2013 EN 55035: 2017

The above equipment has been tested by Shenzhen TCT Testing Technology Co., Ltd. and found compliance with the requirements set forth in the technical standards mentioned above. The results of testing in this report apply only to the product/system, which was tested. Other similar equipment will not necessarily produce the same results due to production tolerance and measurement uncertainties.

Tested By:

Zak

Zak

Date:

Mar. 19, 2019

Check By:

Howie

Howie

Date:

Apr. 12, 2019

Approved By:

Tom

Tom

Date:

Apr. 12, 2019



2. Test Result Summary

Emission		
Test Method	Item	Result
EN 55032: 2015	Conducted Emission at AC Mains Power Ports	Pass
	Conducted Emission at Analogue/Digital Data Ports	N/A
	Conducted Emission at the antenna terminals	N/A
	Wanted signal and emission voltage at the RF output of equipment with incorporated or with add-on RF video modulator	N/A
	Radiated Emission	Pass
EN 61000-3-2: 2014	Harmonic Current Emissions	N/A
EN 61000-3-3: 2013	Voltage Fluctuations & Flicker	N/A

Immunity (EN 55035: 2017)		
Test Method	Item	Result
EN 61000-4-2: 2009	Electrostatic Discharge (ESD)	Pass
EN 61000-4-3: 2006 +A1: 2008+A2: 2010	Radio-frequency Electromagnetic Field Amplitude Modulated (RS)	Pass
EN 61000-4-4: 2012	Electrical Fast Transients (EFT)	Pass
EN 61000-4-5: 2014	Surges	Pass
EN 61000-4-6: 2014	Radio-frequency Continuous Conducted (CS)	Pass
EN 61000-4-8: 2010	Power-frequency Magnetic Fields (PFMF)	N/A
EN 61000-4-11: 2004	Voltage Dips & Voltage Interruptions	Pass

Note:

1. Pass: Test item meets the requirement.
2. Fail: Test item does not meet the requirement.
3. N/A: Test case does not apply to the test object.
4. The test result judgment is decided by the limit of test standard.
5. The information of measurement uncertainty is available upon the customer's request.

3. EUT Description

Product Name:	Document Camera
Model No.:	IRIScan Desk 5
Product Parameter:	Input: DC 5 V/ 1 A Output: DC 5 V, 1 A
AC Mains:	<input type="checkbox"/> Shielded <input type="checkbox"/> Unshielded, <input type="checkbox"/> Detachable <input type="checkbox"/> Un-detachable <input checked="" type="checkbox"/> Not applicable <input type="checkbox"/> Length:
USB Line:	<input type="checkbox"/> Shielded <input checked="" type="checkbox"/> Unshielded, <input checked="" type="checkbox"/> Detachable <input type="checkbox"/> Un-detachable <input type="checkbox"/> Not applicable <input checked="" type="checkbox"/> Length: 2.0 m

4. Test Methodology

4.1. Decision of Final Test Mode

The EUT was tested together with the thereafter additional components, and a configuration, which produced the worst emission levels, was selected and recorded in this report.

The following test mode(s) were assessed:

Test Mode
Mode 1: Working

4.2. EUT System Operation

1. Set up EUT with the support equipments.
2. Make sure the EUT work normally during the test.

5. Setup of Equipment under Test

5.1. Description of Support Units

The EUT has been tested as an independent unit together with other necessary accessories or support units. The following support units or accessories were used to form a representative test configuration during the tests.

Equipment	Model No.	Serial No.	FCC ID	Trade Name
Notebook Computer	XiaoXin CHAO5000	PF0WZYD9	/	Lenovo

Note:

1. All the equipment/cables were placed in the worst-case configuration to maximize the emission during the test.
2. Grounding was established in accordance with the manufacturer's requirements and conditions for the intended use.

5.2. Configuration of System Under Test

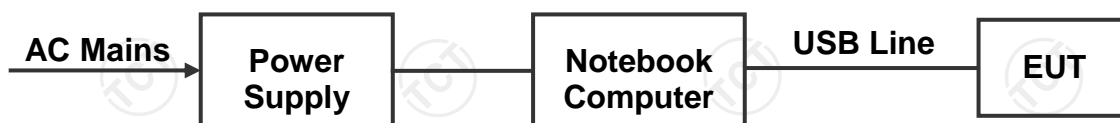

(EUT: Document Camera)

6. Facilities and Accreditations

6.1. Facilities

All measurement facilities used to collect the measurement data are located at TCT Lab.

The sites are constructed in conformance with the requirements of ANSI C63.4 and CISPR Publication 32. All receiving equipment conforms to CISPR Publication 16-1, "Radio Interference Measuring Apparatus and Measurement Methods."

6.2. Measurement Uncertainty

Where relevant, the following measurement uncertainty levels have been estimated for tests performed on the EUT as specified in CISPR 16-4-2:

No.	Item	MU
1.	Temperature	$\pm 0.1^{\circ}\text{C}$
2.	Humidity	$\pm 1.0\%$
3.	Spurious Emissions, Conducted	$\pm 2.56\text{ dB}$
4.	All Emissions, Radiated	$\pm 4.28\text{ dB}$

This uncertainty represents an expanded uncertainty expressed at approximately the 95 % confidence level using a coverage factor of $k=2$.

7. Emission Test

7.1. Conducted Emission at AC Mains Power Ports

7.1.1. Test Specification

Test Requirement:	EN 55032
Test Method:	EN 55032
Frequency Range:	150 kHz to 30 MHz

7.1.2. Limits

Frequency (MHz)	Class A dB(uV)		Class B dB(uV)	
	Quasi-peak	Average	Quasi-peak	Average
0.15 - 0.5	79	66	66 - 56	56 - 46
0.50 - 5.0	73	60	56	46
5.0 - 30.0	73	60	60	50

7.1.3. Test Instruments

Conducted Emission Shielding Room Test Site (843)				
Equipment	Manufacturer	Model	Serial Number	Calibration Due
EMI Test Receiver	R&S	ESPI	101402	Jul. 17, 2019
LISN	Schwarzbeck	NSLK 8126	8126453	Sep. 20, 2019
Attenuator	N/A	10dB	164080	Sep. 16, 2019
Coaxial Cable	TCT	CE-05	N/A	Sep. 16, 2019

Note: The calibration interval of the above test instruments is 12 months and the calibrations are traceable to international system unit (SI).

7.1.4. Test Method

The AMN was placed 0.8 m from the boundary of the unit under test and bonded to a ground reference plane. This distance was between the closest points of the AMN and the EUT. All other units of the EUT and associated equipment was at least 0.8 m from the AMN. All power was connected to the system through Artificial Mains Network (AMN). Conducted voltage measurements on mains lines were made at the output of the AMN.

7.1.5. Block Diagram of Test Setup

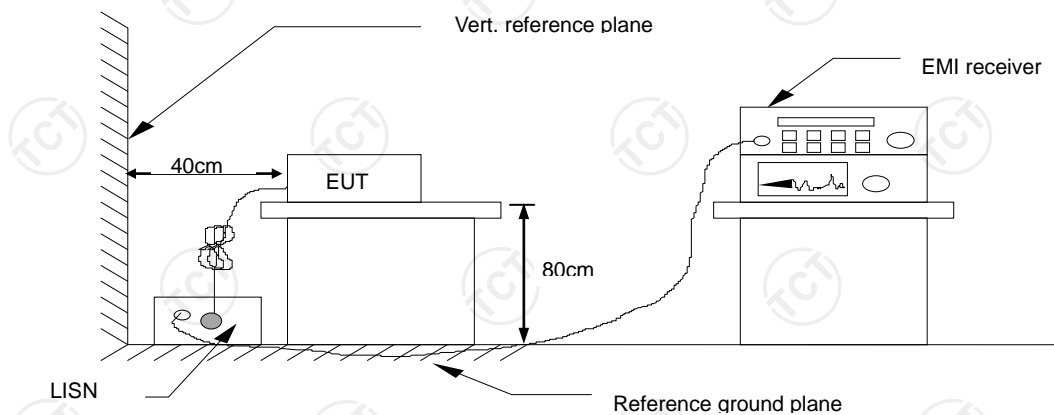

For the actual test configuration, please refer to the related item – Photographs of the Test Configuration.

7.1.6. Test Results

Test Environment:	Temp.: 25 °C	Humid.: 55 %	Press.: 96 kPa
Test Mode:	Mode 1		
Test Voltage:	DC 5 V (Notebook Computer Input AC 230 V ± 10 V & AC 110 V ± 10 V, 50/ 60 Hz)		
Remark:	The worst case show in this report		
Test Result:	Pass		

Note:

L1 = Live Line / N = Neutral Line

Freq. = Emission frequency in MHz

Reading level (dBμV) = Receiver reading

Correct Factor (dB) = LISN factor + Cable loss

Measurement (dBμV) = Reading level (dBμV) + Corr. Factor (dB)

Limit (dBμV) = Limit stated in standard

Margin (dB) = Measurement (dBμV) – Limits (dBμV)

Q.P. =Quasi-Peak AVG =average

* is meaning the worst frequency has been tested in the frequency range 150 kHz to 30MHz.

Please refer to following diagram for individual

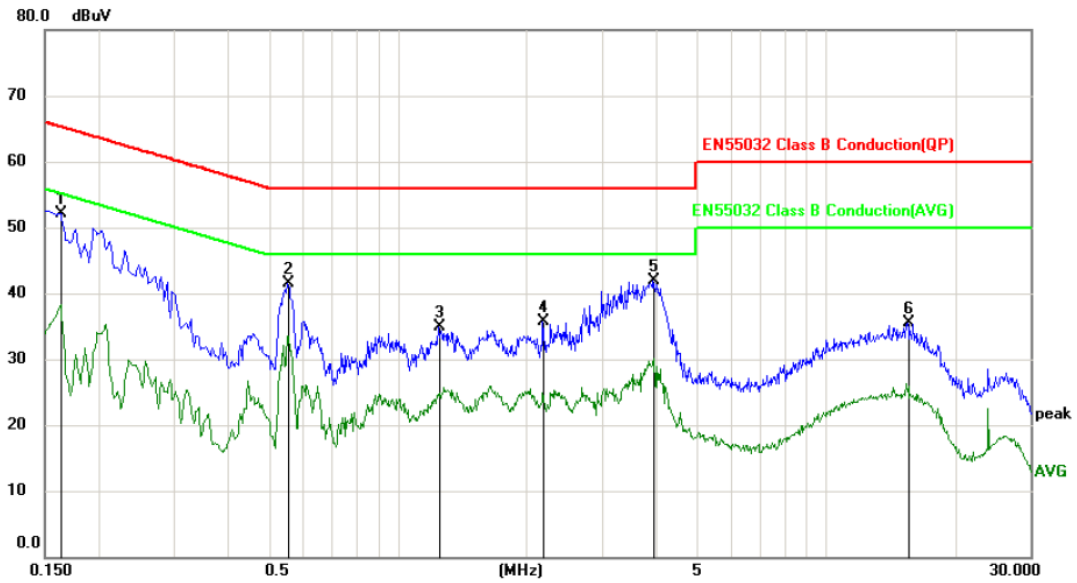

Site: _____ Phase: **L1** Temperature: 25
 Limit: EN55032 Class B Conduction(QP) Power: _____ Humidity: 55 %
 Mode: Working
 Note: DC 5V(Notebook Computer Input AC 230V/50Hz)

No.	Mk.	Freq. MHz	Reading Level dBuV	Correct Factor dB	Measure- ment dBuV	Limit dBuV	Over dB	Detector	Comment
1	*	0.1635	51.97	0.22	52.19	65.28	-13.09	peak	
2		0.5550	41.25	0.23	41.48	56.00	-14.52	peak	
3		1.2479	34.50	0.38	34.88	56.00	-21.12	peak	
4		2.1794	35.31	0.45	35.76	56.00	-20.24	peak	
5		3.9435	41.34	0.47	41.81	56.00	-14.19	peak	
6		15.5175	34.63	0.83	35.46	60.00	-24.54	peak	

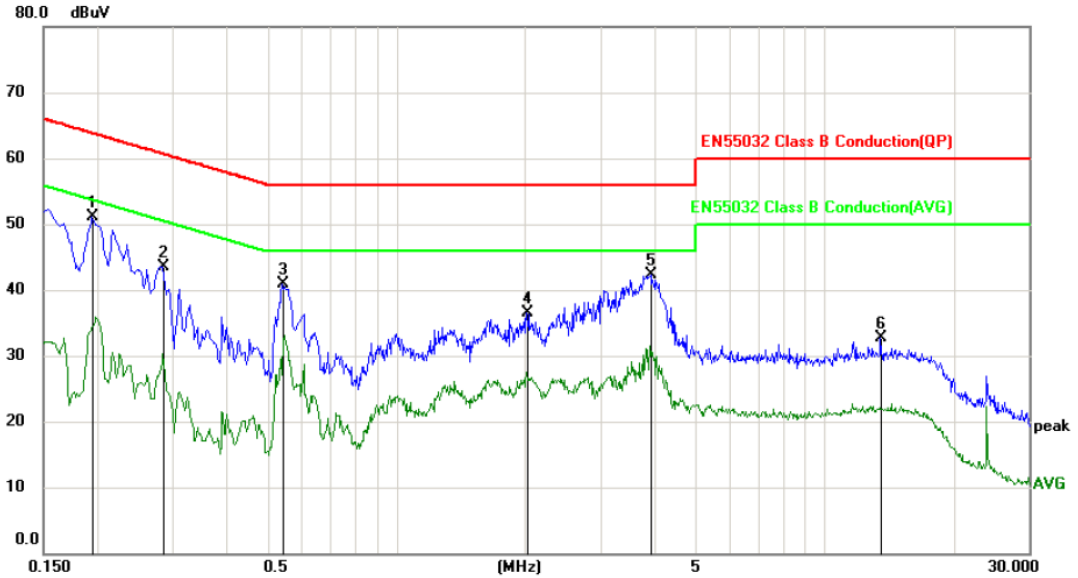

Site: Phase: *N* Temperature: 25
 Limit: EN55032 Class B Conduction(QP) Power: Humidity: 55 %
 Mode: Working
 Note: DC 5V(Notebook Computer Input AC 230V/50Hz)

No.	Mk.	Freq. MHz	Reading Level dBuV	Correct Factor dB	Measure- ment dBuV	Limit dBuV	Over dB	Detector	Comment
1	*	0.1949	50.82	0.22	51.04	63.83	-12.79	peak	
2		0.2849	43.31	0.23	43.54	60.67	-17.13	peak	
3		0.5415	40.69	0.22	40.91	56.00	-15.09	peak	
4		2.0173	36.08	0.45	36.53	56.00	-19.47	peak	
5		3.9390	41.77	0.47	42.24	56.00	-13.76	peak	
6		13.5015	31.98	0.68	32.66	60.00	-27.34	peak	

7.2. Conducted Emission at Analogue/Digital Data Ports

7.2.1. Test Specification

Test Requirement:	EN 55032
Test Method:	EN 55032
Frequency Range:	150 kHz to 30 MHz

7.2.2. Limits

Ports Types	Optical Fibre Ports with metallic shield or tension members			
	Wired Network Ports			
Cables Types	Balanced Unscreened, Screened or Coaxial			
Frequency (MHz)	Voltage limits Class A dB(uV)		Current limits Class A dB(uA)	
	Quasi-peak	Average	Quasi-peak	Average
0.15 - 0.5	97 - 87	84 - 74	53 - 43	40 - 30
0.5 - 30.0	87	74	43	30

Ports Types	Optical Fibre Ports with metallic shield or tension members			
	Wired Network Ports			
Cables Types	Balanced Unscreened, Screened or Coaxial			
Frequency (MHz)	Voltage limits Class B dB(uV)		Current limits Class B dB(uA)	
	Quasi-peak	Average	Quasi-peak	Average
0.15 - 0.5	84 - 74	74 - 64	40 - 30	30 - 20
0.5 - 30.0	74	64	30	20

Note:

1. Applicable to ports listed above and intended to connect to cables longer than 3 m.

7.2.3. Test Instruments

Conducted Emission Shielding Room Test Site (843)				
Equipment	Manufacturer	Model	Serial Number	Calibration Due
EMI Test Receiver	R&S	ESPI	101402	Jul. 17, 2019
ISN	R&S	ENY81	100054	Aug. 27, 2019
ISN	R&S	ENY81-CA6	101564	Aug. 27, 2019
Current probe	Schwarzbeck	F-33-2	427	Aug. 27, 2019

Note: The calibration interval of the above test instruments is 12 months and the calibrations are traceable to international system unit (SI).

7.2.4. Test Method

All power was connected to the system through Artificial Mains Network (AMN). All tested telecommunications lines were connected to an Impedance Stabilization Network (ISN) and conducted voltage measurements on telecommunications lines were made at the output of the ISN. Where an ISN was not appropriate or available measurements were made using a Capacitive Voltage Probe and Current probe.

7.2.5. Block Diagram of Test Setup

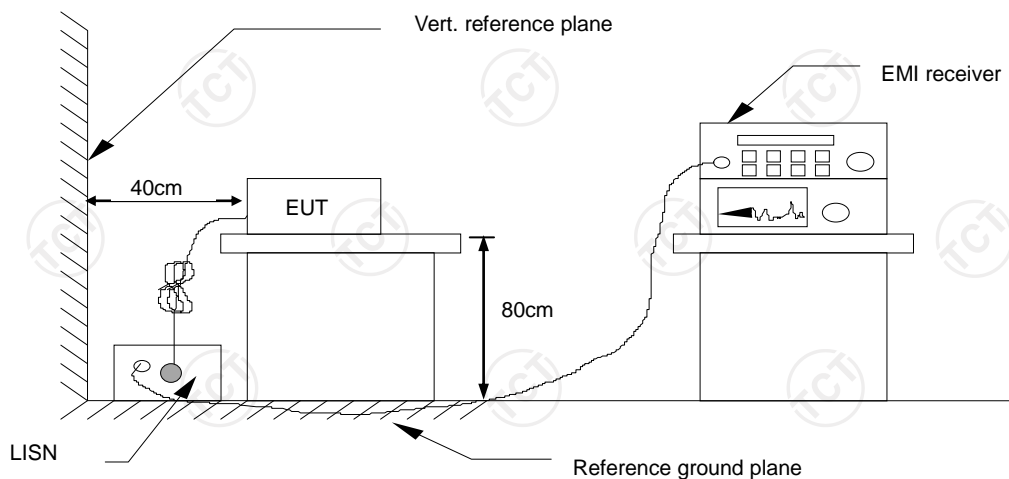

For the actual test configuration, please refer to the related item – Photographs of the Test Configuration.

7.2.6. Test Results

Note: This test isn't applicable because the EUT doesn't have relative function.

7.3. Conducted Emission at the antenna terminals

7.3.1. Test Specification

Test Requirement:	EN 55032
Test Method:	EN 55032
Frequency Range:	30 MHz to 2150 MHz

7.3.2. Limits

Frequency range MHz	Detector type/ bandwidth	Class B limits dB(μV) 75 Ω			Applicability
		Other	Local Oscillator Fundamental	Local Oscillator Harmonics	
30 to 950	For frequencies ≤1 GHz	48	48	48	See ^a
950 to 2 150		48	54	54	
950 to 2 150		Quasi Peak/ 120 kHz	48	54	54
30 to 300	48		54	50	See ^c
300 to 1 000	For frequencies ≥1 GHz	48	68	52	
30 to 300				59	
300 to 1 000				52	
30 to 950	Peak/ 1 MHz	48	78	48	See ^e
950 to 2 150			n/a	54	

^a Television receivers (analogue or digital), video recorders and PC TV broadcast receiver tuner cards working in channels between 30 MHz and 1 GHz, and digital audio receivers.

^b Tuner units (not the LNB) for satellite signal reception.

^c Frequency modulation audio receivers and PC tuner cards.

^d Frequency modulation car radios.

^e Applicable to EUTs with RF modulator output ports (for example DVD equipment, video recorders, camcorders and decoders etc.) designed to connect to TV broadcast receiver tuner ports. Limits specified for the LO are for the RF modulator carrier signal and harmonics.

7.3.3. Test Instruments

Discontinuous Disturbance Shielding Room Test Site (843)				
Equipment	Manufacturer	Model	Serial Number	Calibration Due
EMI Test Receiver	R&S	ESPI	101402	Jul. 17, 2019
Spectrum Analyzer	HP	8594EM	3710A00269	Aug. 27, 2019
TV Signal Generator	Fluke	PM5418	LO 800003	Sep. 16, 2019

Note: The calibration interval of the above test instruments is 12 months and the calibration can be traced to international system unit (SI).

7.3.4. Test Method

The measurement was performed in accordance with the requirement set in Annex C. 4.2. The antenna terminal of the sample and the signal generator were connected to the EMI receiver by means of coaxial cables and a resistive combining network having a minimum attenuation of 6 dB.

7.3.5. Block Diagram of Test Setup

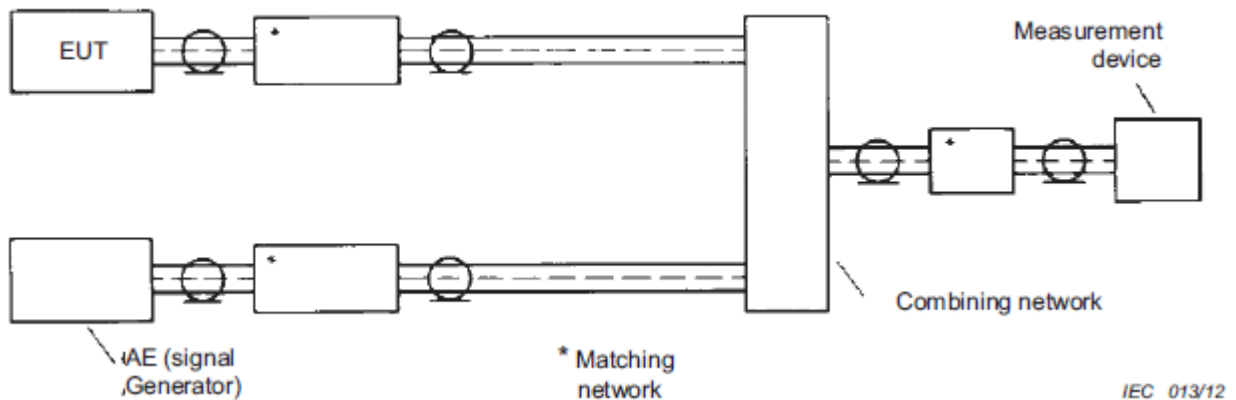

For the actual test configuration, please refer to the related item – Photographs of the Test Configuration

7.3.6. Test Results

Note: This test isn't applicable because the EUT doesn't have relative function.

7.4. Wanted signal and emission voltage at the RF output of equipment with incorporated or with add-on RF video modulator

7.4.1. Test Specification

Test Requirement:	EN 55032
Test Method:	EN 55032
Frequency Range:	30 MHz to 2150 MHz

7.4.2. Limits

Frequency range MHz	Detector type/ bandwidth	Class B limits dB(μV) 75 Ω			Applicability
		Other	Local Oscillator Fundamental	Local Oscillator Harmonics	
30 to 950	For frequencies ≤1 GHz	48	48	48	See ^a
950 to 2 150		48	54	54	
950 to 2 150		Quasi Peak/ 120 kHz	48	54	54
30 to 300	48		54	50	See ^c
300 to 1 000	For frequencies ≥1 GHz			52	
30 to 300		48	88	59	See ^d
300 to 1 000				52	
30 to 950	Peak/ 1 MHz	48	78	48	See ^e
950 to 2 150			n/a	54	

^a Television receivers (analogue or digital), video recorders and PC TV broadcast receiver tuner cards working in channels between 30 MHz and 1 GHz, and digital audio receivers.

^b Tuner units (not the LNB) for satellite signal reception.

^c Frequency modulation audio receivers and PC tuner cards.

^d Frequency modulation car radios.

^e Applicable to EUTs with RF modulator output ports (for example DVD equipment, video recorders, camcorders and decoders etc.) designed to connect to TV broadcast receiver tuner ports. Limits specified for the LO are for the RF modulator carrier signal and harmonics.

7.4.3. Test Instruments

Discontinuous Disturbance Shielding Room Test Site (843)				
Equipment	Manufacturer	Model	Serial Number	Calibration Due
EMI Test Receiver	R&S	ESPI	101402	Jul. 17, 2019
TV Signal Generator	Fluke	PM5418	LO 800003	Sep. 16, 2019

Note: The calibration interval of the above test instruments is 12 months and the calibration can be traced to international system unit (SI).

7.4.4. Test Method

The measurement was performed in accordance with the requirement set in Annex C. 4.3.

The RF modulator output port of the EUT is connected to the input of the measuring device by means of a coaxial cable and a matching network (if necessary).

The characteristic impedance of the cable shall be equal to the nominal output impedance of the EUT. The RF output level shall be obtained by adding the insertion loss of the matching network to the indication of the measuring device (tuned to the video carrier frequency and its harmonics).

7.4.5. Block Diagram of Test Setup

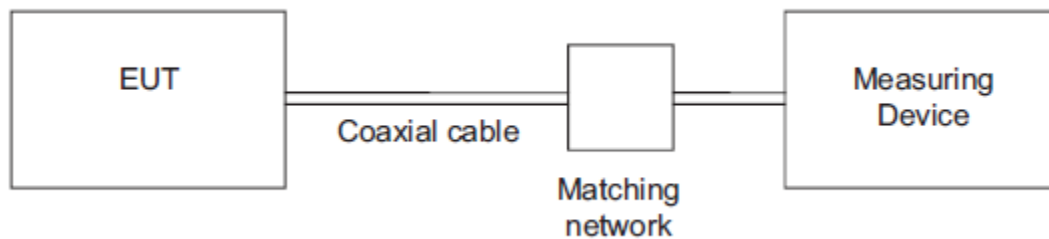

IEC 014/12

For the actual test configuration, please refer to the related item – Photographs of the Test Configuration

7.4.6. Test Results

Note: This test isn't applicable because the EUT doesn't have relative function.

7.5. Radiated Emission

7.5.1. Test Specification

Test Requirement:	EN 55032
Test Method:	EN 55032
Frequency Range:	30 MHz to 1000 MHz
Measurement Distance:	3 m
Antenna Polarization:	Horizontal & Vertical

7.5.2. Limits

Below 1 GHz

Frequency (MHz)	dB(uV/m) (At 3m)	
	Class A	Class B
30 - 230	50	40
230 - 1000	57	47

Note: 1. The lower limit shall apply at the transition frequency.
2. Additional provisions may be required for cases where interference occurs.

Above 1 GHz

Frequency (GHz)	Class A		Class B	
	Average dB(uV/m)	Peak dB(uV/m)	Average dB(uV/m)	Peak dB(uV/m)
1 - 3	56	76	50	70
3 - 6	60	80	54	74

Note: The lower limit shall apply at the transition frequency.

7.5.3. Test Instruments

Radiated Emission Test Site (966)				
Name of Equipment	Manufacturer	Model	Serial Number	Calibration Due
EMI Test Receiver	R&S	ESIB7	100197	Jul. 17, 2019
Spectrum Analyzer	R&S	FSQ40	200061	Sep. 20, 2019
Amplifier	HP	8447D	2727A05017	Sep. 16, 2019
Amplifier	EM Electronics Corporation CO.,LTD	EM30265	07032613	Sep. 16, 2019
Broadband Antenna	Schwarzbeck	VULB9163	340	Sep. 02, 2019
Horn Antenna	Schwarzbeck	BBHA 9120D	631	Oct. 20, 2019
Coaxial Cable	TCT	RE-low-01	N/A	Sep. 16, 2019

Coaxial Cable	TCT	RE-high-02	N/A	Sep. 16, 2019
Coaxial Cable	TCT	RE-low-03	N/A	Sep. 16, 2019
Coaxial Cable	TCT	RE-high-04	N/A	Sep. 16, 2019

Note: The calibration interval of the above test instruments is 12 months and the calibrations are traceable to international system unit (SI).

7.5.4. Test Method

Measurements were made in a 3-meter semi-anechoic chamber. Preliminary (peak) measurements were performed at an antenna to EUT separation distance of 3 meter. The EUT was rotated 360° about its azimuth with the receive antenna located at various heights in horizontal and vertical polarities. Final measurements (quasi-peak) were then performed by rotating the EUT 360° and adjusting the receive antenna height from 1 to 4 m. All frequencies were investigated in both horizontal and vertical antenna polarity, where applicable. Block Diagram of Test Setup.

7.5.5. Block Diagram of Test Setup

For 3m distance description:

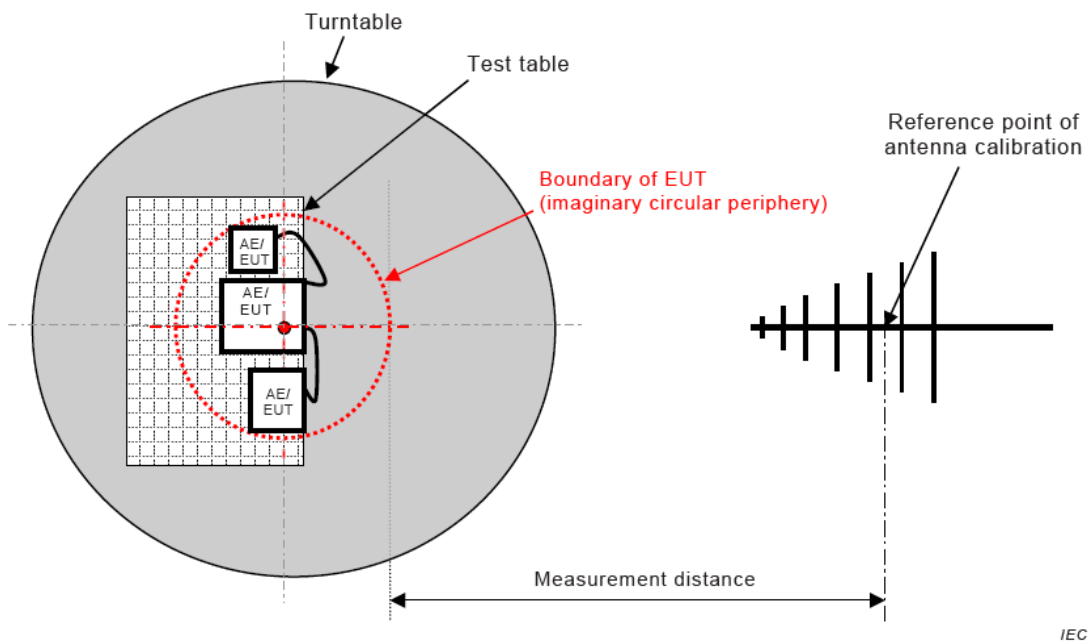

Figure C.1 – Measurement distance

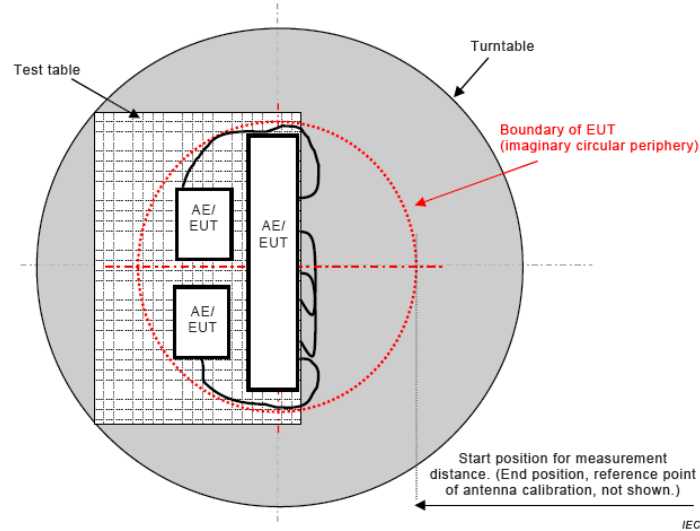
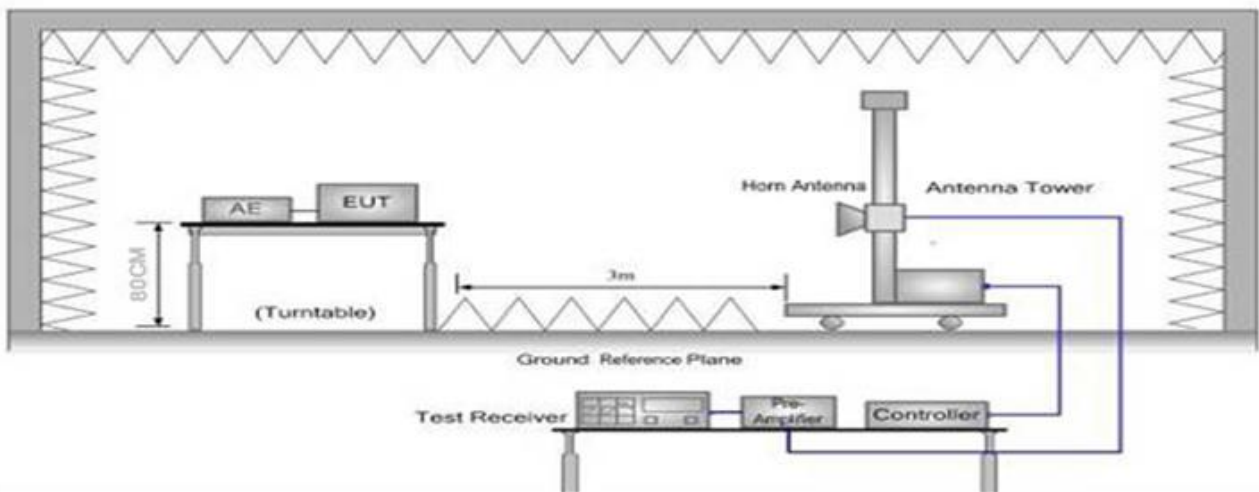

Figure C.2 – Boundary of EUT, Local AE and associated cabling



For the actual test configuration, please refer to the related item – Photographs of the Test Configuration.

7.5.6. Test Results

Test Environment:	Temp.:	25 °C	Humid.:	55 %	Press.:	96 kPa
Test Mode:	Mode 1					
Test Voltage:	DC 5 V (Notebook Computer Input AC 230 V ± 10 V & AC 110 V ± 10 V, 50/ 60 Hz)					
Remark:	The worst case show in this report					
Test Result:	Pass					

Note:

Freq. = Emission frequency in MHz

Reading level (dBµV/m) = Receiver reading

Corr. Factor (dB) = Antenna Factor + Cable Loss - AMP Factor

Measurement (dBµV/m) = Reading level (dBµV/m) + Corr. Factor (dB)

Limit (dBµV/m) = Limit stated in standard

Margin (dB) = Measurement (dBµV/m) – Limit (dBµV/m)

* is meaning the worst frequency has been tested in the test frequency range

Please refer to following diagram for individual

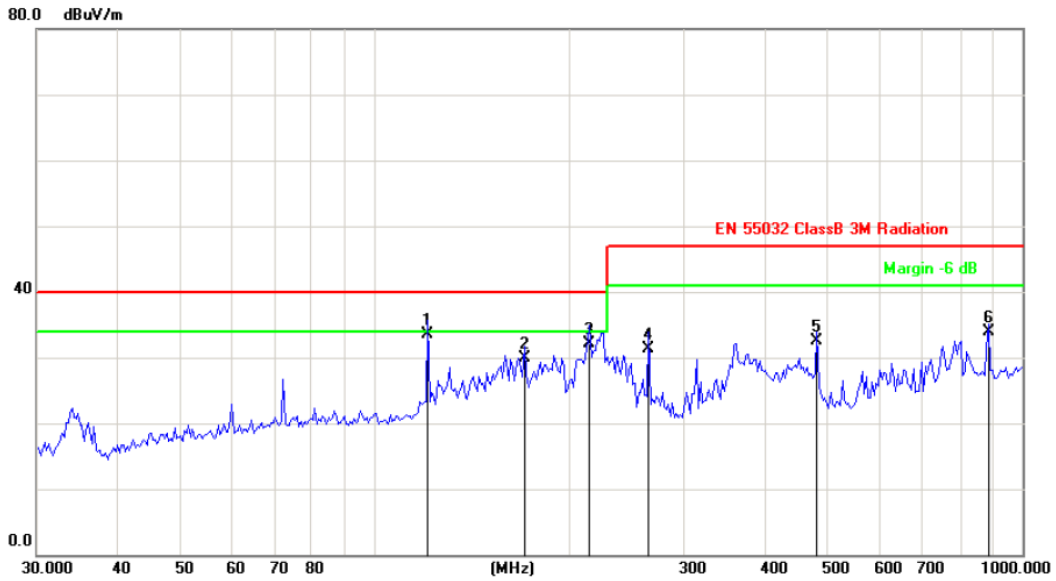

Site: Polarization: **Horizontal** Temperature: 25
 Limit: EN 55032 ClassB 3M Radiation Power: Humidity: 55 %
 Mode: Working
 Note: DC 5V(Notebook Computer Input AC 230V/50Hz)

No.	Mk.	Freq.	Reading Level	Correct Factor	Measurement	Limit	Over	Antenna Height	Table Degree	
		MHz	dBuV	dB	dBuV/m	dB/m	dB	cm	degree	Comment
1	*	120.6118	45.22	-11.78	33.44	40.00	-6.56	QP		
2		170.1887	45.33	-15.35	29.98	40.00	-10.02	QP		
3		214.6063	45.62	-13.59	32.03	40.00	-7.97	QP		
4		264.9709	43.33	-12.07	31.26	47.00	-15.74	QP		
5		481.5112	40.22	-7.74	32.48	47.00	-14.52	QP		
6		887.3976	37.22	-3.41	33.81	47.00	-13.19	QP		



Site: Polarization: **Vertical** Temperature: 25
 Limit: EN 55032 ClassB 3M Radiation Power: Humidity: 55 %
 Mode: Working
 Note: DC 5V(Notebook Computer Input AC 230V/50Hz)

No.	Mk.	Freq.	Reading Level	Correct Factor	Measurement	Limit	Over	Antenna Height	Table Degree	
		MHz	dBuV	dB	dBuV/m	dB/m	dB	cm	degree	Comment
1		72.2111	43.22	-15.87	27.35	40.00	-12.65	QP		
2	*	120.6118	47.33	-11.78	35.55	40.00	-4.45	QP		
3	!	223.8482	48.32	-13.32	35.00	40.00	-5.00	QP		
4		360.9775	35.22	-9.53	25.69	47.00	-21.31	QP		
5		481.5112	40.25	-7.74	32.51	47.00	-14.49	QP		
6		787.4749	34.22	-4.61	29.61	47.00	-17.39	QP		



7.6. Harmonic Current Emissions

7.6.1. Test Specification

Test Requirement:	EN 61000-3-2
Test Method:	EN 61000-3-2
Limits:	Class A

7.6.2. Test Instruments

Harmonic Test Equipment				
Name of Equipment	Manufacturer	Model	Serial Number	Calibration Due
AC Power Supply	KIKUSUI	PCR4000M	UC002552	Sep. 20, 2019
Harmonic/Flicker Analyzer	KIKUSUI	KHA1000	UD002324	Sep. 20, 2019
Multi Outlet Unit	KIKUSUI	OT01-KHA	UF003026	Sep. 20, 2019
Line Impedance Network	KIKUSUI	LIN1020JF	UC001738	Sep. 20, 2019

Note: The calibration interval of the above test instruments is 12 months and the calibrations are traceable to international system unit (SI).

7.6.3. Block Diagram of Test Setup

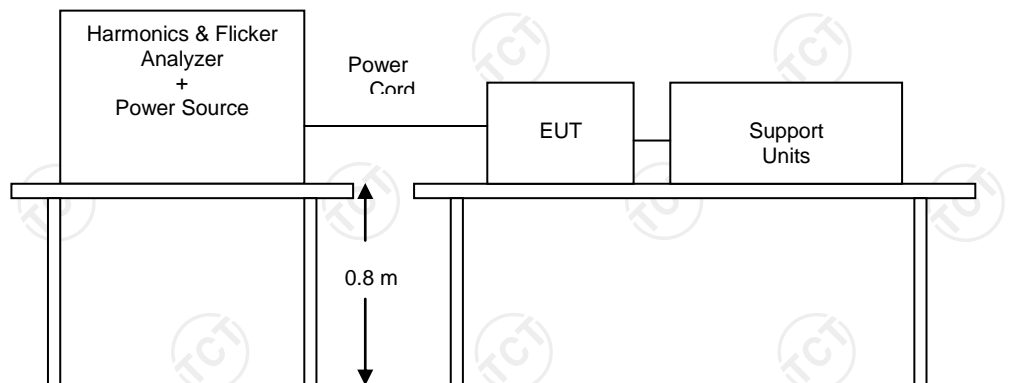

For the actual test configuration, please refer to the related item – Photographs of the Test Configuration.

7.6.4. Test Results

Note: This test isn't applicable because the EUT doesn't have relative function.

7.7. Flicker and Voltage Fluctuation

7.7.1. Test Specification

Test Requirement:	EN 61000-3-3
Test Method:	EN 61000-3-3

7.7.2. Limits

Test Item	Limit	Note
Pst	1.0	Pst means short-term flicker indicator
Plt	0.65	Plt means long-term flicker indicator
Tdt (ms)	500	Tdt means maximum time that dt exceeds 3 %.
dmax (%)	4/6/7	Dmax means maximum relative voltage change.
dc (%)	3.3	Dc means relative steady-state voltage change.

7.7.3. Test Instruments

Flicker Test Equipment				
Name of Equipment	Manufacturer	Model	Serial Number	Calibration Due
AC Power Supply	KIKUSUI	PCR4000M	UC002552	Sep. 20, 2019
Harmonic/Flicker Analyzer	KIKUSUI	KHA1000	UD002324	Sep. 20, 2019
Multi Outlet Unit	KIKUSUI	OT01-KHA	UF003026	Sep. 20, 2019
Line Impedance Network	KIKUSUI	LIN1020JF	UC001738	Sep. 20, 2019

Note: The calibration interval of the above test instruments is 12 months and the calibrations are traceable to international system unit (SI).

7.7.4. Block Diagram of Test Setup

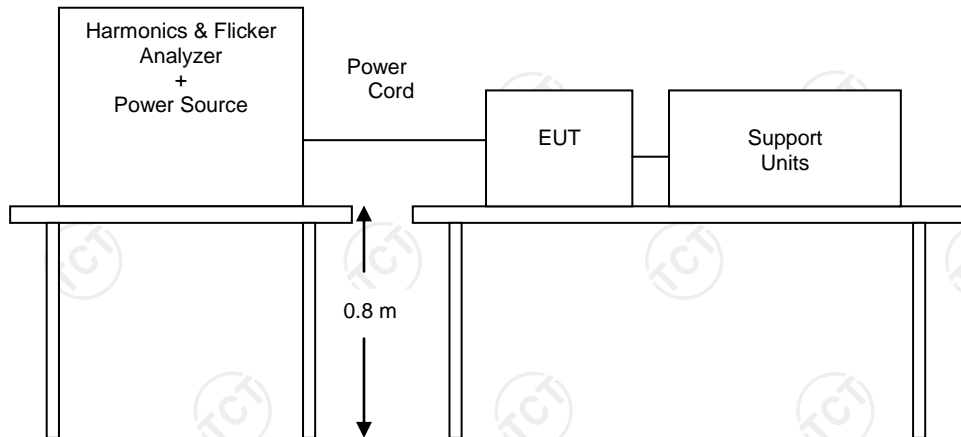

For the actual test configuration, please refer to the related item – Photographs of the Test Configuration.

7.7.5. Test Results

Note: This test isn't applicable because the EUT doesn't have relative function.

8. Immunity Test

8.1. General Performance Criteria Description

<p>Criterion A:</p>	<p>The equipment shall continue to operate as intended without operator intervention. No degradation of performance, loss of function or change of operating state is allowed below a performance level specified by the manufacturer when the equipment is used as intended. The performance level may be replaced by a permissible loss of performance. If the minimum performance level or the permissible performance loss is not specified by the manufacturer, then either of these may be derived from the product description and documentation, and by what the user may reasonably expect from the equipment if used as intended.</p>
<p>Criterion B:</p>	<p>During the application of the disturbance, degradation of performance is allowed. However, no unintended change of actual operating state or stored data is allowed to persist after the test.</p> <p>After the test, the equipment shall continue to operate as intended without operator intervention; no degradation of performance or loss of function is allowed, below a performance level specified by the manufacturer, when the equipment is used as intended. The performance level may be replaced by a permissible loss of performance.</p> <p>If the minimum performance level (or the permissible performance loss), or recovery time, is not specified by the manufacturer, then either of these may be derived from the product description and documentation, and by what the user may reasonably expect from the equipment if used as intended.</p>
<p>Criterion C:</p>	<p>Loss of function is allowed, provided the function is self-recoverable, or can be restored by the operation of the controls by the user in accordance with the manufacturer's instructions. A reboot or re-start operation is allowed</p> <p>Information stored in non-volatile memory, or protected by a battery backup, shall not be lost.</p>

8.2. Electrostatic Discharge (ESD)

8.2.1. Test Specification

Test Requirement:	EN 55035
Test Method:	EN 61000-4-2
Storage capacitor:	150 pF
Discharge resistor:	330 ohm
Discharge Voltage:	Contact Discharge: ± 4 kV Air Discharge: ± 8 kV HCP/VCP: ± 4 kV
Polarity:	Positive & Negative
Number of Discharge:	Minimum 20 times at each test points
Discharge Mode:	1 time/s
Performance Criterion:	B

8.2.2. Test Instruments

Immunity Shielded Room				
Name of Equipment	Manufacturer	Model	Serial Number	Calibration Due
Electrostatic Discharge Generator	Prima	ESD61002AG	PR12092502	Sep. 27, 2019

Note: The calibration interval of the above test instruments is 12 months and the calibrations are traceable to international system unit (SI).

8.2.3. Test Method

1. Air Discharge:

The test was applied on non-conductive surfaces of EUT. The round discharge tip of the discharge electrode was approached as fast as possible to touch the EUT. After each discharge, the discharge electrode was removed from the EUT. The generator was re-triggered for a new single discharge and repeated 20 times for each pre-selected test point. This Method was repeated until all the air discharge completed.

2. Contact Discharge:

The test was applied on accessible metallic parts of the EUT. The generator was re-triggered for a new single discharge and repeated 20 times for each pre-selected test point. The tip of the discharge electrode was touching the EUT before the discharge switch was operated.

3. Indirect discharge for horizontal coupling plane:

At least 10 single discharges (in the most sensitive polarity) were applied to the horizontal coupling plane, at points on each side of the EUT. The discharge electrode positions vertically at a distance of 0.1 m from the EUT and with the discharge electrode touching the coupling plane.

4. Indirect discharge for vertical coupling plane:

At least 10 single discharges (in the most sensitive polarity) were applied to the center of one vertical edge of the coupling plane. The coupling plane, of dimensions 0.5 m X 0.5 m, was placed parallel to, and positioned at a distance of 0.1 m from the EUT. Discharges were applied to the coupling plane, with this plane in sufficient different positions that the four faces of the EUT are completely illuminated.

8.2.4. Block Diagram of Test Setup

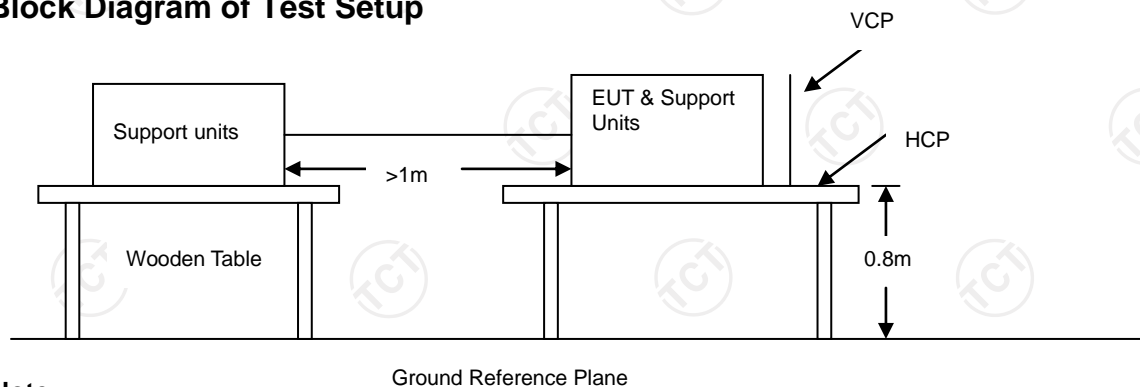

Note:

1. Table-top Equipment

The configuration consisted of a wooden table 0.8 meters high standing on the **Ground Reference Plane**. The **GRP** consisted of a sheet of aluminum at least 0.25 mm thick, and 2.5 meters square connected to the protective grounding system. A **Horizontal Coupling Plane** (1.6 m x 0.8 m) was placed on the table and attached to the **GRP** by means of a cable with 940 k total impedance.

The equipment under test was installed in a representative system as described in section 7 of EN 61000-4-2, and its cables were placed on the **HCP** and isolated by an insulating support of 0.5 mm thickness. A distance of 1-meter minimum was provided between the EUT and the walls of the laboratory and any other metallic structure.

2. Floor-standing Equipment

The equipment under test was installed in a representative system as described in section 7 of EN 61000-4-2, and its cables were isolated from the Ground Reference Plane by an insulating support of 0.1-meter thickness. The GRP consisted of a sheet of aluminum that is at least 0.25 mm thick, and 2.5 meters square connected to the protective grounding system and extended at least 0.5 meters from the EUT on all sides.

8.2.5. Test Results

Test Environment:	Temp.:	25 °C	Humid.:	55 %	Press.:	96 kPa
Test Mode:	Mode 1					
Test Voltage:	DC 5 V (Notebook Computer Input AC 230 V/ 50 Hz)					
Test Result:	Pass					

Test points:	I: Please refer to red rings as below plots
	II: Please refer to yellow rings and arrows as below plots

Direct Discharge					
Discharge Voltage (KV)	Type of discharge	Test points	Performance Criterion	Observation	Results
± 8	Air	I	B	Note <input type="checkbox"/> 1 <input checked="" type="checkbox"/> 2 <input type="checkbox"/> 3	Pass
± 4	Contact	II	B	Note <input type="checkbox"/> 1 <input checked="" type="checkbox"/> 2 <input type="checkbox"/> 3	Pass

Indirect Discharge					
Discharge Voltage (KV)	Illuminated area of the EUT surface	Test points	Performance Criterion	Observation	Results
± 4	Top/ Bottom /Front/Back /Left/Right	HCP	B	Note <input type="checkbox"/> 1 <input checked="" type="checkbox"/> 2 <input type="checkbox"/> 3	Pass
± 4	Front/ Back/Left /Right	VCP	B	Note <input type="checkbox"/> 1 <input checked="" type="checkbox"/> 2 <input type="checkbox"/> 3	Pass

Note:

1. There was no change compared with initial operation during and after the test. No unintentional response was found during the test.
2. The function stopped during the test, but can be recoverable by itself operation after the test.
3. The function stopped during the test, but can be recoverable manually after the test.

Test point as follows:

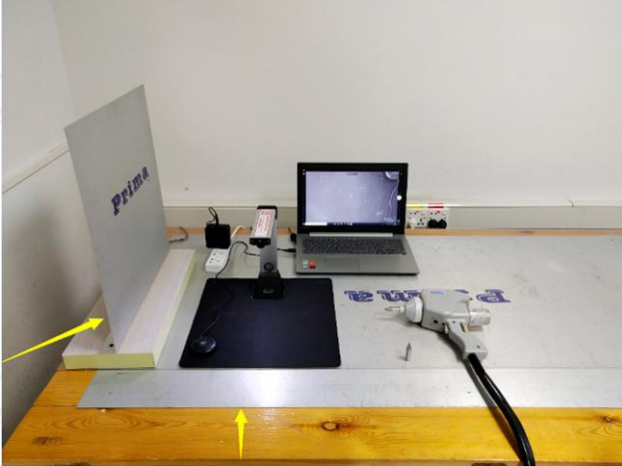

8.3. Radio-frequency Electromagnetic Field Amplitude Modulated (RS)

8.3.1. Test Specification

Test Requirement:	EN 55035
Test Method	EN 61000-4-3
Frequency Range:	80 MHz -1000 MHz
Test level:	3 V/m (unmodulated, r.m.s)
Modulation:	1 kHz, 80 % AM, sine wave
Frequency Step:	1 % of preceding frequency value
Polarity of Antenna:	Horizontal & Vertical
Antenna Height:	1.5 m
Performance Criterion:	A

8.3.2. Test Instruments

966 RS Chamber				
Name of Equipment	Manufacturer	Model	Serial Number	Calibration Due
Signal Generator	Maconi	2022D	119246/003	Sep. 27, 2019
Power Amplifier	M2S	A00181-1000	9801-112	Sep. 27, 2019
Power Amplifier	M2S	AC8113/ 800-250A	9801-179	Sep. 27, 2019
Power Antenna	SCHAFFNER	CBL6140A	1204	Sep. 27, 2019

Note: The calibration interval of the above test instruments is 12 months and the calibrations are traceable to international system unit (SI).

8.3.3. Test Method

1. The testing was performed in a fully anechoic chamber. The transmit antenna was located at a distance of 3 meters from the EUT.
2. The frequency range is swept from 80 MHz to 1000 MHz, 1800 MHz, 2500 MHz, 3500 MHz, 5000 MHz, with the signal 80% amplitude modulated with a 1 kHz sine-wave. The rate of sweep did not exceed 1.5×10^{-3} decade/s, where the frequency range is swept incrementally; the step size was 1% of preceding frequency value.
3. The dwell time at each frequency shall not be less than the time necessary for the EUT to be exercised and to be able to respond. However, the dwell time should not exceed 5 s at each of the frequencies during the scan.
4. The test was performed with the EUT exposed to both vertically and horizontally polarized fields on each of the four sides.

5. The EUT was performed in a configuration to actual installation conditions, a video camera and/or an audio monitor were used to monitor the performance of the EUT.

8.3.4. Block Diagram of Test Setup

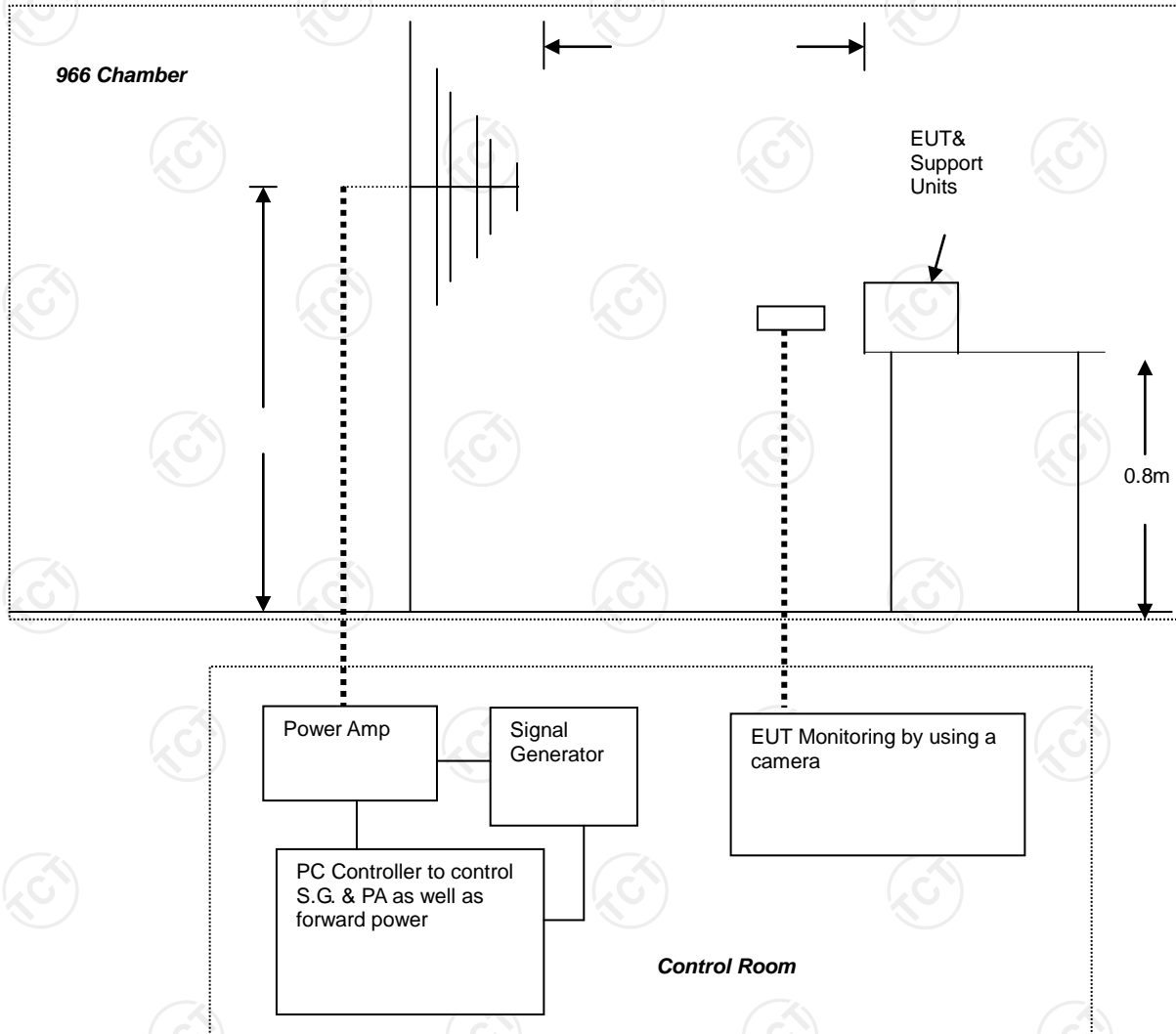

Note:

1. Table-top Equipment

The EUT installed in a representative system as described in section 7 of EN 61000-4-3 was placed on a non-conductive table 0.8 meters in height. The system under test was connected to the power and signal wire according to relevant installation instructions.

2. Floor-standing Equipment

The EUT installed in a representative system as described in section 7 of IEC 61000-4-3 was placed on a non-conductive wood support 0.1 meters in height. The system under test was connected to the power and signal wire according to relevant installation instructions.

8.3.5. Test Results

Test Environment:	Temp.:	25 °C	Humid.:	55 %	Press.:	96 kPa
Test Mode:	Mode 1					
Test Voltage:	DC 5 V (Notebook Computer Input AC 230 V/ 50 Hz)					
Test Result:	Pass					

Frequency(MHz)	Polarity	Position	Field Strength(V/m)	Observation
80 ~ 1000 MHz	V&H	Front	3	Note <input checked="" type="checkbox"/> 1 <input type="checkbox"/> 2 <input type="checkbox"/> 3
80 ~ 1000 MHz	V&H	Rear	3	Note <input checked="" type="checkbox"/> 1 <input type="checkbox"/> 2 <input type="checkbox"/> 3
80 ~ 1000 MHz	V&H	Left	3	Note <input checked="" type="checkbox"/> 1 <input type="checkbox"/> 2 <input type="checkbox"/> 3
80 ~ 1000 MHz	V&H	Right	3	Note <input checked="" type="checkbox"/> 1 <input type="checkbox"/> 2 <input type="checkbox"/> 3

Note:

1. There was no change compared with initial operation during and after the test. No unintentional response was found during the test.
2. The function stopped during the test, but can be recoverable by itself operation after the test.
3. The function stopped during the test, but can be recoverable manually after the test.

8.4. Electrical Fast Transient (EFT)

8.4.1. Test Specification

Test Requirement:	EN 55035
Test Method:	EN 61000-4-4
Test Level:	analogue/digital data ports: ± 0.5 kV (peak) input d.c. power port: ± 0.5 kV (peak) input a.c. power ports: ± 1 kV (peak)
Polarity:	Positive & Negative
Impulse Frequency:	5 kHz
Impulse Wave-shape:	5/50 ns
Burst Duration:	15 ms
Burst Period:	300 ms
Test Duration:	2 minutes per level & polarity
Performance Criterion:	B

8.4.2. Test Instruments

Immunity Shield Room				
Name of Equipment	Manufacturer	Model	Serial Number	Calibration Due
Fast Transient Burst Simulator	Prima	EFT61004BG	PR12074375	Sep. 20, 2019
Capacitive coupling folder	Prima	EFT-CLAMP	N/A	Sep. 20, 2019
Single-phase transformer	Prima	JMB-3KVA	L12121902-2	Sep. 20, 2019

Note: The calibration interval of the above test instruments is 12 months and the calibrations are traceable to international system unit (SI).

8.4.3. Test Method

1. The EUT and its simulators were placed on the ground reference plane and were insulated from it by a wood support 0.1 m + 0.01 m thick. The ground reference plane was 1 m*1 m metallic sheet with 0.65 mm minimum thickness.
2. This reference ground plane was project beyond the EUT by at least 0.1 m on all sides and the minimum distance between EUT and all other conductive structure, except the ground plane was more than 0.5 m.
3. All cables to the EUT was placed on the wood support, cables not subject to EFT/B was routed as far as possible from the cable under test to minimize the coupling between the cables.

4. The length of the signal and power lines between the coupling device and the EUT is 0.5 m.
5. The EUT is connected to the power mains through a coupling device that directly couples the EFT/B interference signal.
6. Each of the Line and Neutral conductors is impressed with burst noise for 2 minutes.

8.4.4. Block Diagram of Test Setup

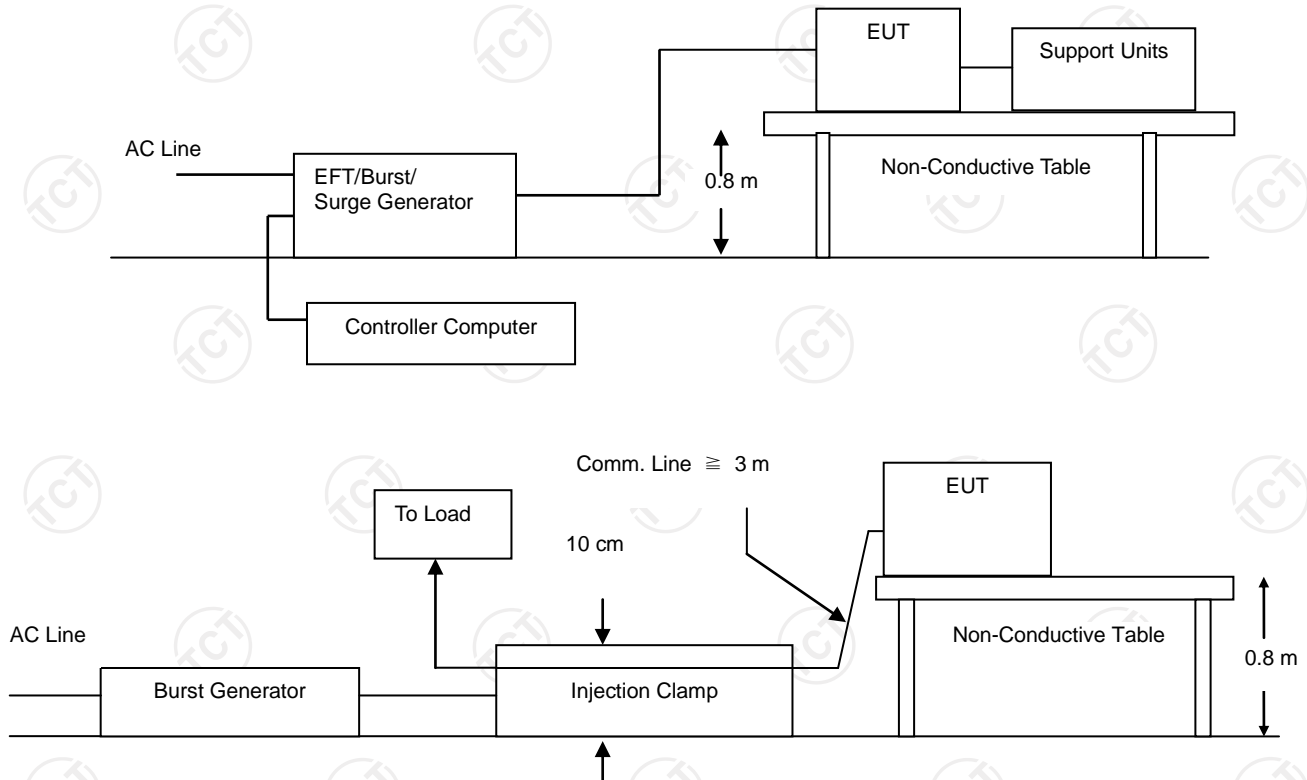

Note:

1. Table-top Equipment

The configuration consisted of a wooden table (0.8 m high) standing on the Ground Reference Plane. The GRP consisted of a sheet of aluminum (at least 0.25 mm thick and 2.5 m square) connected to the protective grounding system. A minimum distance of 0.5 m was provided between the EUT and the walls of the laboratory or any other metallic structure.

2. Floor-standing Equipment

The EUT installed in a representative system as described in section 7 of IEC 61000-4-4 and its cables, were isolated from the Ground Reference Plane by an insulating support that is 0.1-meter thick. The GRP consisted of a sheet of aluminum (at least 0.25 mm thick and 2.5 m square) connected to the protective grounding system.

8.4.5. Test Results

Test Environment:	Temp.:	25 °C	Humid.:	55 %	Press.:	96 kPa
Test Mode:	Mode 1					
Test Voltage:	DC 5 V (Notebook Computer Input AC 230 V/ 50 Hz)					
Test Result:	Pass					

Test Point	Polarity	Test Level (kV)	Performance Criterion	Observation
L	+/-	1	B	Note <input type="checkbox"/> 1 <input checked="" type="checkbox"/> 2 <input type="checkbox"/> 3
N	+/-	1	B	Note <input type="checkbox"/> 1 <input checked="" type="checkbox"/> 2 <input type="checkbox"/> 3
L -N	+/-	1	B	Note <input type="checkbox"/> 1 <input checked="" type="checkbox"/> 2 <input type="checkbox"/> 3
PE	--	--	--	N/A
L – PE	--	--	--	N/A
N – PE	--	--	--	N/A
L – N – PE	--	--	--	N/A
DC Port	--	--	--	N/A
analogue/digital data ports	--	--	--	N/A

Note:

1. There was no change compared with initial operation during and after the test. No unintentional response was found during the test.
2. The function stopped during the test, but can be recoverable by itself operation after the test.
3. The function stopped during the test, but can be recoverable manually after the test.

8.5. Surges

8.5.1. Test Specification

Test Requirement:	EN 55035
Test Method:	EN 61000-4-5
Test Level:	analogue/digital data ports: $\pm 1/4$ kV(peak) input d.c. power port: ± 0.5 kV (peak) input a.c. power ports: Line to line: ± 1 kV(peak) Line to ground: ± 2 kV(peak)
Polarity:	Positive & Negative
Wave-Shape:	1.2/50 us; 8 /20 us; 10 /700 us
Generator Source Impedance:	2 ohm between networks 12 ohm between network and ground
Test Interval:	60 s between each surge
Number of Tests:	5 positive, 5 negative at 0°, 90°, 180°, 270°.
Performance Criterion:	B&C

8.5.2. Test Instruments

Immunity Shield Room				
Name of Equipment	Manufacturer	Model	Serial Number	Calibration Due
Lightning Surge Generator	Prima	SUG61005BG	PR12125534	Sep. 20, 2019
Single-phase transformer	Prima	JMB-3KVA	L12121902-2	Sep. 20, 2019

Note: The calibration interval of the above test instruments is 12 months and the calibrations are traceable to international system unit (SI).

8.5.3. Test Method

- For line-to-line coupling mode, provide a 1 kV 1.2/50 us voltage surge (at open-circuit condition) and 8/20 us current surge to EUT selected points, and for active line / neutral lines to ground are same except test level is 2 kV.
- At least 5 positive and 5 negative (polarity) tests with a maximum 1/min repetition rate are applied during test.
- Different phase angles are done individually.
- Record the EUT operating situation during compliance test and decide the EUT immunity criterion for above each test.

8.5.4. Block Diagram of Test Setup

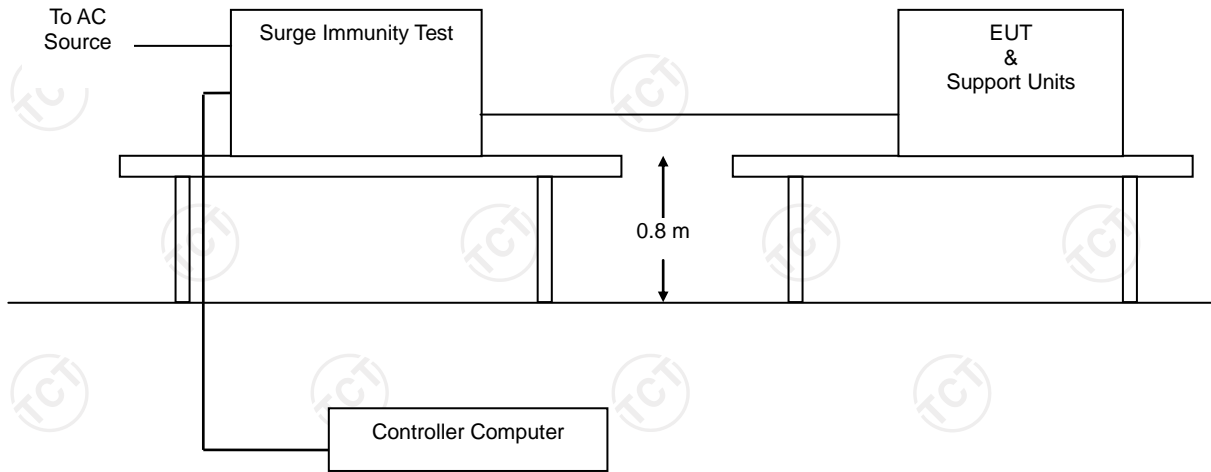

8.5.5. Test Results

Test Environment:	Temp.:	25 °C	Humid.:	55 %	Press.:	96 kPa
Test Mode:	Mode 1					
Test Voltage:	DC 5 V (Notebook Computer Input AC 230 V/ 50 Hz)					
Test Result:	Pass					

Test Point	Polarity	Test Level (kV)	Performance Criterion	Observation
L - N	+/-	1	B	Note <input type="checkbox"/> 1 <input checked="" type="checkbox"/> 2 <input type="checkbox"/> 3
L - PE	--	--	--	N/A
N - PE	--	--	--	N/A
DC Port	--	--	--	N/A
analogue/digital data ports	--	--	--	N/A

Note:

1. There was no change compared with initial operation during and after the test. No unintentional response was found during the test.
2. The function stopped during the test, but can be recoverable by itself operation after the test.
3. The function stopped during the test, but can be recoverable manually after the test.

8.6. Radio-frequency Continuous Conducted (CS)

8.6.1. Test Specification

Test Requirement:	EN 55035
Test Method	EN 61000-4-6
Frequency Ranges, Test Level:	0.15 MHz - 10 MHz, 3 V rms (unmodulated) 10 MHz - 30 MHz, 3 V to 1 V rms (unmodulated) 30 MHz - 80 MHz, 1 V rms (unmodulated)
Modulation:	1 kHz, 80 % AM, sine wave
Performance Criterion:	A

8.6.2. Test Instrument

CS Test				
Name of Equipment	Manufacturer	Model	Serial Number	Calibration Due
Conducted Disturbances Test System	Schloder	CDG 6000-75	126B1290	Sep. 20, 2019
CDN	Schloder	CDN M2+M3-16	A2210281	Sep. 20, 2019
Attenuator	PE	PE7017-6	N/A	Jul. 17, 2019
EM-Clamp	Schloder	EMCL-20	132A1194	Sep. 20, 2019

Note: The calibration interval of the above test instruments is 12 months and the calibrations are traceable to international system unit (SI).

8.6.3. Test Method

1. The EUT are placed on an insulating support 0.1 m high above a ground reference plane. CDN (coupling and decoupling device) is placed on the ground plane about 0.3 m from EUT. Cables between CDN and EUT are as short as possible, and their height above the ground reference plane shall be between 30 and 50 mm (where possible).
2. The disturbance signal described below is injected to EUT through CDN.
3. The EUT operates within its operational mode(s) under intended climatic conditions after power on.
4. The frequency range is swept from 0.15 MHz to 80 MHz using 3 V to 1 V signal level, and with the disturbance signal 80 % amplitude modulated with a 1 kHz sine wave.

5. Recording the EUT operating situation during compliance testing and decide the EUT immunity criterion.

8.6.4. Block Diagram of Test Setup

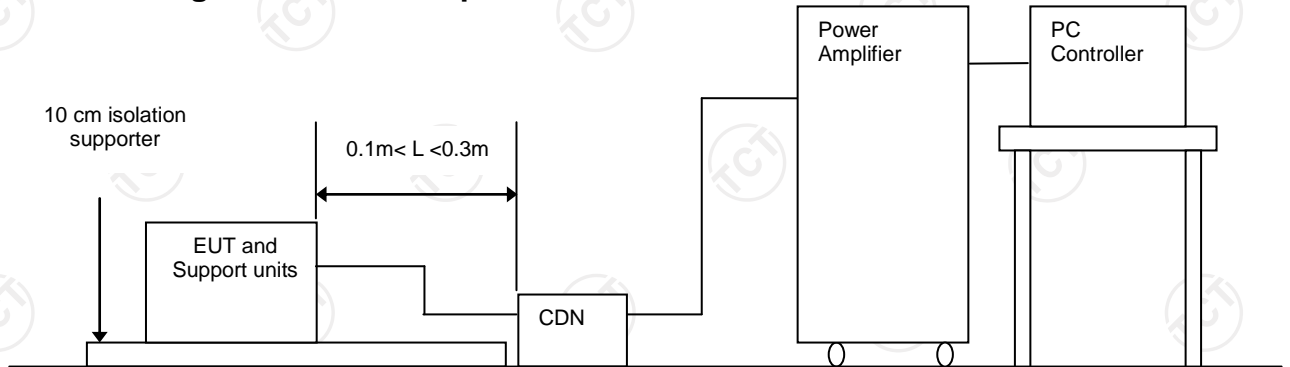

Note:

Table-Top and Floor-Standing Equipment

The equipment to be tested is placed on an insulating support of 0.1 meters height above a ground reference plane. All relevant cables shall be provided with the appropriate coupling and decoupling devices at a distance between 0.1 meters and 0.3 meters from the projected geometry of the EUT on the ground reference plane.

8.6.5. Test Results

Test Environment:	Temp.:	25 °C	Humid.:	55 %	Press.:	96 kPa
Test Mode:	Mode 1					
Test Voltage:	DC 5 V (Notebook Computer Input AC 230 V/ 50 Hz)					
Test Result:	Pass					

Frequency Band (MHz)	Field Strength (Vrms)	Injected Position	Injection Method	Performance Criterion	Observation
0.15 ~ 10	3	AC Mains	CDN-M2	A	Note <input checked="" type="checkbox"/> 1 <input type="checkbox"/> 2 <input type="checkbox"/> 3
10 ~ 30	3 ~ 1	AC Mains	CDN-M2	A	Note <input checked="" type="checkbox"/> 1 <input type="checkbox"/> 2 <input type="checkbox"/> 3
30 ~ 80	1	AC Mains	CDN-M2	A	Note <input checked="" type="checkbox"/> 1 <input type="checkbox"/> 2 <input type="checkbox"/> 3

Note:

1. There was no change compared with initial operation during and after the test. No unintentional response was found during the test.
2. The function stopped during the test, but can be recoverable by itself operation after the test.
3. The function stopped during the test, but can be recoverable manually after the test.

8.7. Power-frequency Magnetic Field (PFMF)

8.7.1. Test Specification

Test Requirement:	EN 55035
Test Method:	EN 61000-4-8
Frequency:	50/60 Hz
Test level:	1 A/m
Observation Time:	5 minutes
Performance criterion:	A

8.7.2. Test Instrument

Immunity Shield Room				
Name of Equipment	Manufacturer	Model	Serial Number	Calibration Due
Power Frequency Magnetic Field Generator	EVERFINE	EMS61000-8K	G121941CS13 41114	Sep. 16, 2019
Adjustable Magnetic Field Coil	EVERFINE	MFC-4	G1242BBS134 1114	Sep. 16, 2019

Note: The calibration interval of the above test instruments is 12 months and the calibrations are traceable to international system unit (SI).

8.7.3. Test Method

1. the equipment is configured and connected to satisfy its functional requirements. It shall be placed on the GRP with the interposition of a 0.1 m-thick insulating support.
2. the equipment cabinets shall be connected to the safety earth directly on the GRP via the earth terminal of the EUT.
3. the power supply, input and output circuits shall be connected to the sources of power supply, control and signal.
4. the cables supplied or recommended by the equipment manufacturer shall be used. 1 meter of all cables used shall be exposed to the magnetic field.

8.7.4. Block Diagram of Test Setup

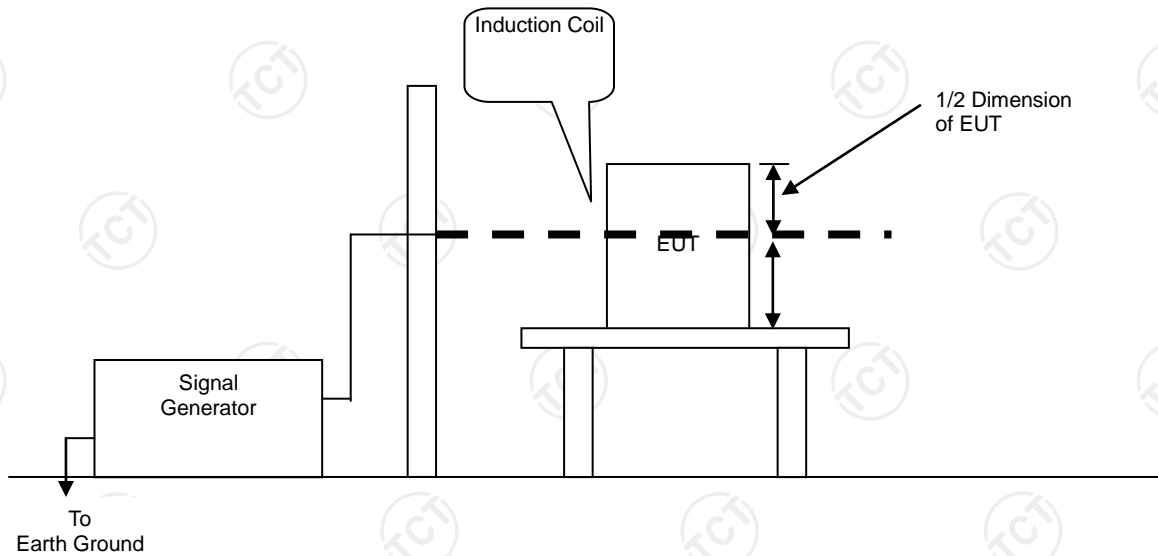

Note:

1. Table-top Equipment

The equipment shall be subjected to the test magnetic field by using the induction coil of standard dimension (1 m x 1 m). The induction coil shall then be rotated by 90 degrees in order to expose the EUT to the test field with different orientations.

2. Floor-standing Equipment

The equipment shall be subjected to the test magnetic field by using induction coils of suitable dimensions. The test shall be repeated by moving and shifting the induction coils, in order to test the whole volume of the EUT for each orthogonal direction. The test shall be repeated with the coil shifted to different positions along the side of the EUT, in steps corresponding to 50 % of the shortest side of the coil. The induction coil shall then be rotated by 90 degrees in order to expose the EUT to the test field with different orientations.

8.7.5. Test Results

Note: This test isn't applicable because the EUT doesn't have relative function.

8.8. Voltage Dip & Voltage Interruptions

8.8.1. Test Specification

Test Requirement:	EN 55035
Test Level:	0% of U_T (Supply Voltage) for 0.5 periods 70% of U_T (Supply Voltage) for 25 periods 0 % of U_T (Supply Voltage) for 250 periods
Performance Criterion:	B&C

8.8.2. Test Instrument

Immunity shielded room				
Name of Equipment	Manufacturer	Model	Serial Number	Calibration Due
Cycle Sag Simulator	Prima	DRP61011AG	PR12106201	Sep. 20, 2019
Single-phase transformer	Prima	JMB-3KVA	L12121902-2	Sep. 20, 2019

Note: The calibration interval of the above test instruments is 12 months and the calibrations are traceable to international system unit (SI).

8.8.3. Test Method

1. The EUT and support units were located on a wooden table, 0.8 m away from ground floor.
2. Setting the parameter of tests and then perform the test software of test simulator.
3. Conditions changes to occur at 0 degree crossover point of the voltage waveform.
4. Recording the test result in test record form.

8.8.4. Block Diagram of Test Setup

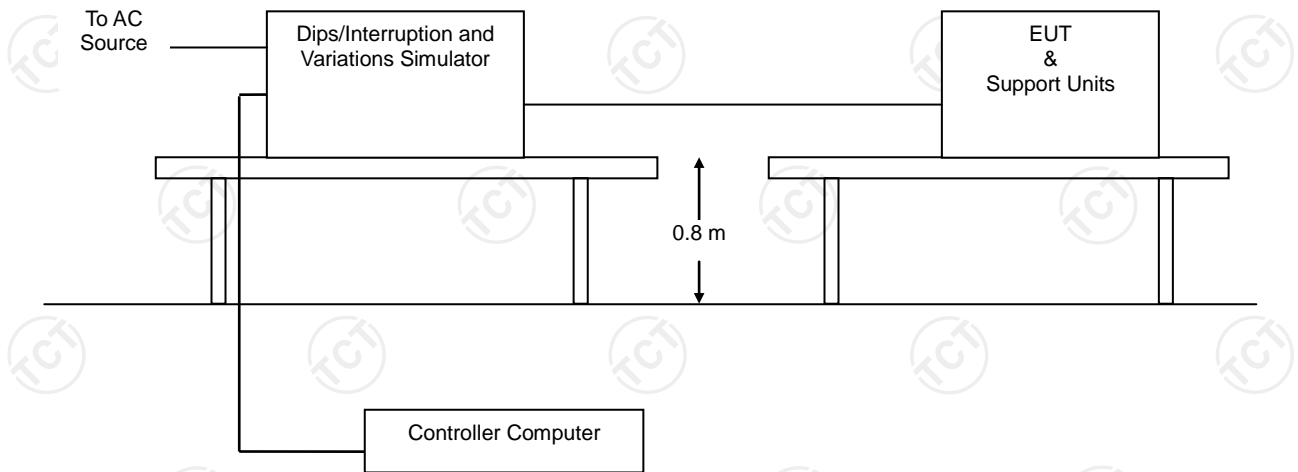

8.8.5. Test Results

Test Environment:	Temp.:	25 °C	Humid.:	55 %	Press.:	96 kPa
Test Mode:	Mode 1					
Test Voltage:	DC 5 V (Notebook Computer Input AC 230 V/ 50 Hz)					
Test Result:	Pass					

Voltage (%Reduction)	Duration (cycle)	Performance Criterion	Observation
100	0.5	<input type="checkbox"/> A <input checked="" type="checkbox"/> B <input type="checkbox"/> C	Note <input type="checkbox"/> 1 <input checked="" type="checkbox"/> 2 <input type="checkbox"/> 3
30	25	<input type="checkbox"/> A <input type="checkbox"/> B <input checked="" type="checkbox"/> C	Note <input type="checkbox"/> 1 <input type="checkbox"/> 2 <input checked="" type="checkbox"/> 3
100	250	<input type="checkbox"/> A <input type="checkbox"/> B <input checked="" type="checkbox"/> C	Note <input type="checkbox"/> 1 <input type="checkbox"/> 2 <input checked="" type="checkbox"/> 3

Note:

1. There was no change compared with initial operation during and after the test. No unintentional response was found during the test.
2. The function stopped during the test, but can be recoverable by itself operation after the test.
3. The function stopped during the test, but can be recoverable manually after the test.

9. Photographs of Test Configuration

Conducted Emission Test View

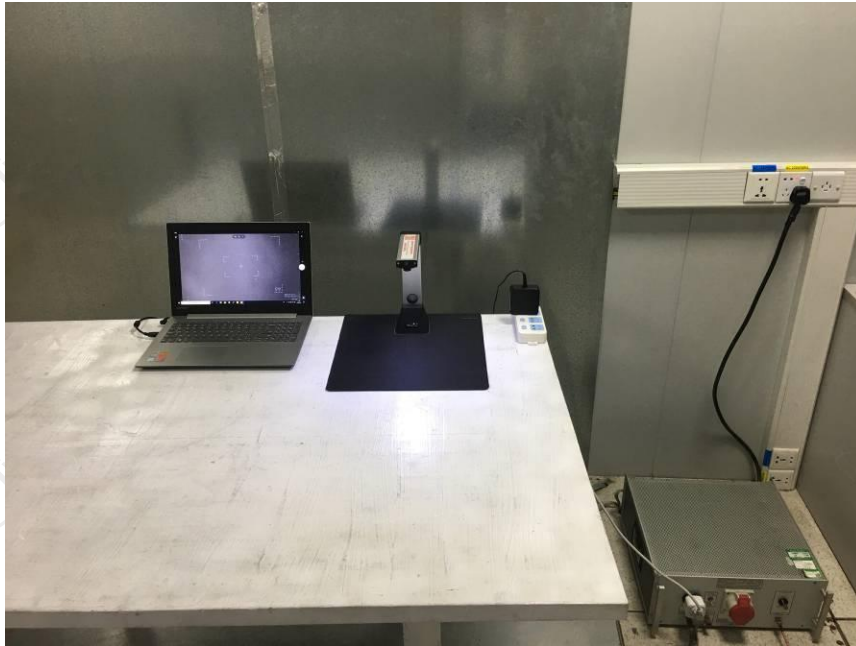

Radiated Emission Test View



ESD Test View

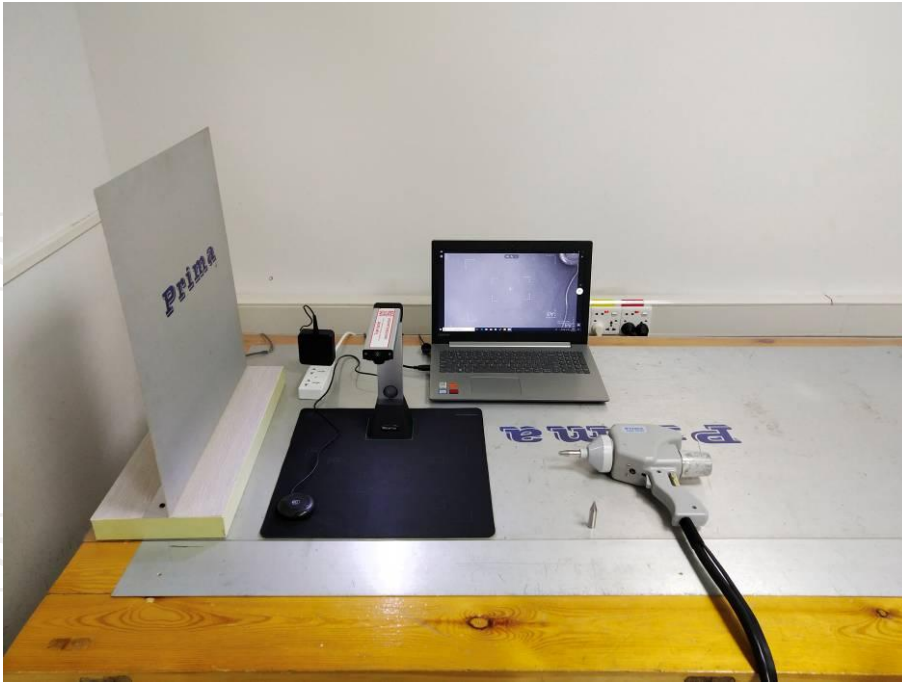

EFT Test View

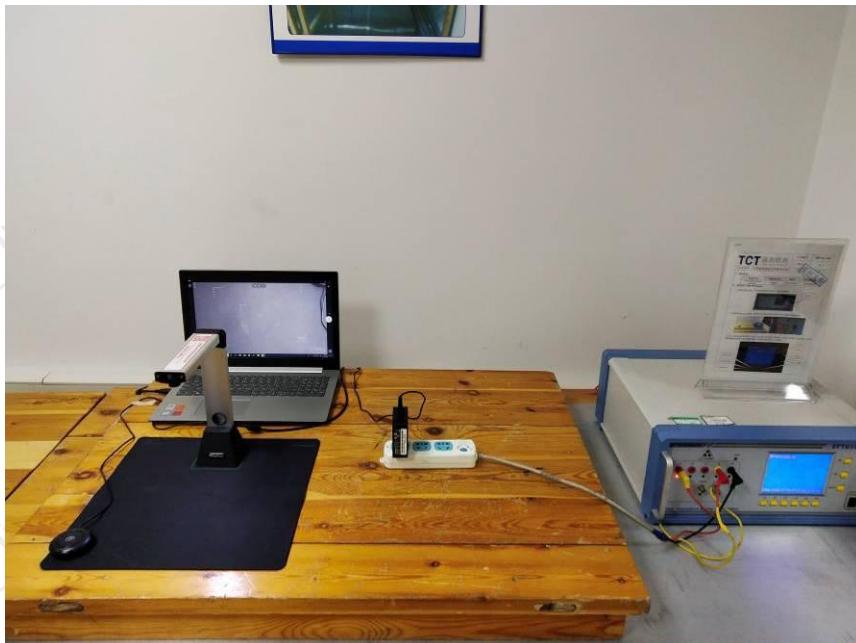

Surges Test View

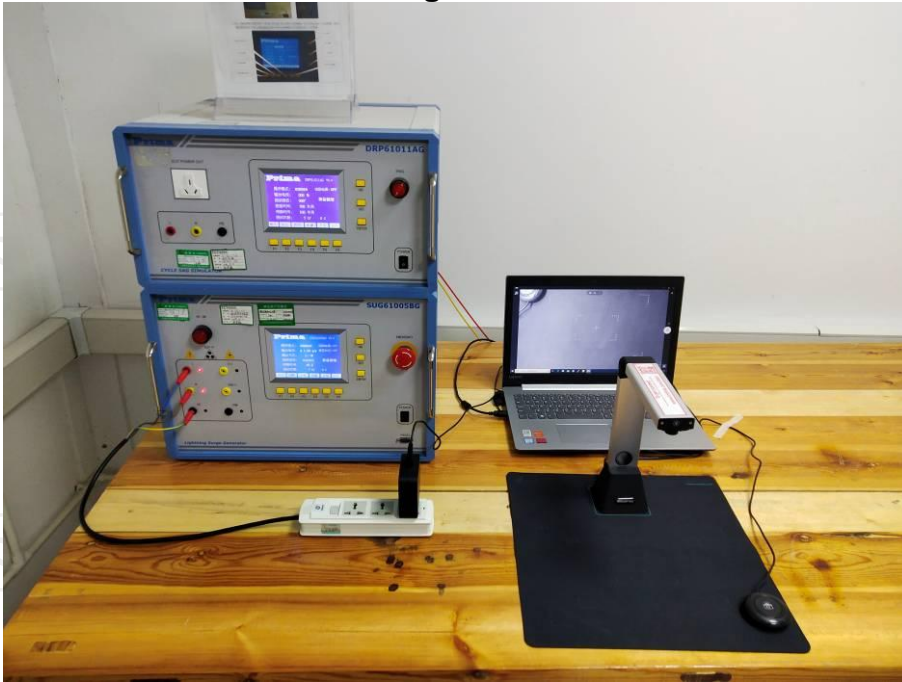

CS Test View



Voltage Dips/Interruptions Test View



10. Photographs of EUT

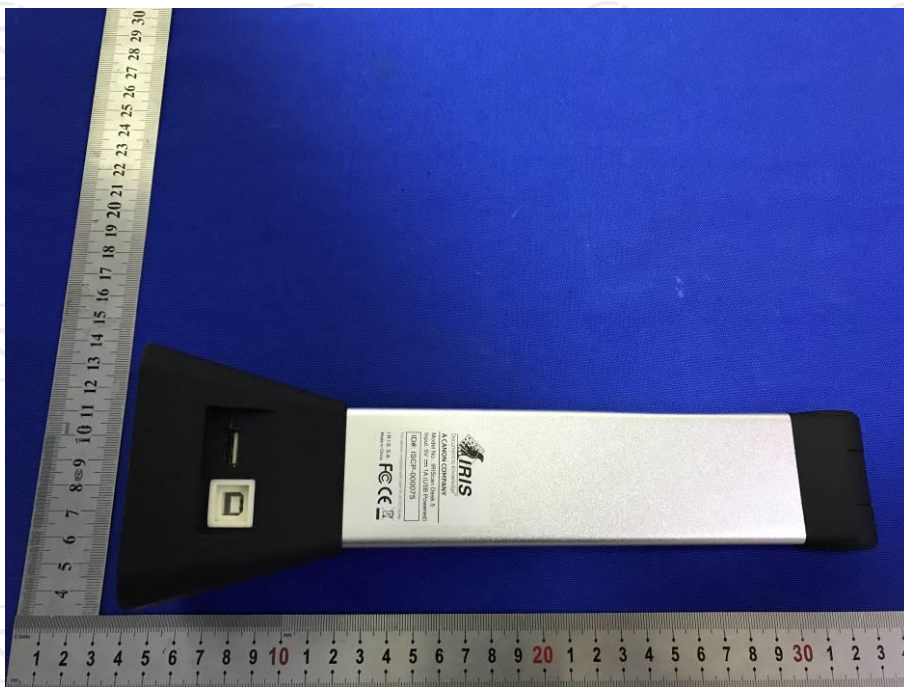

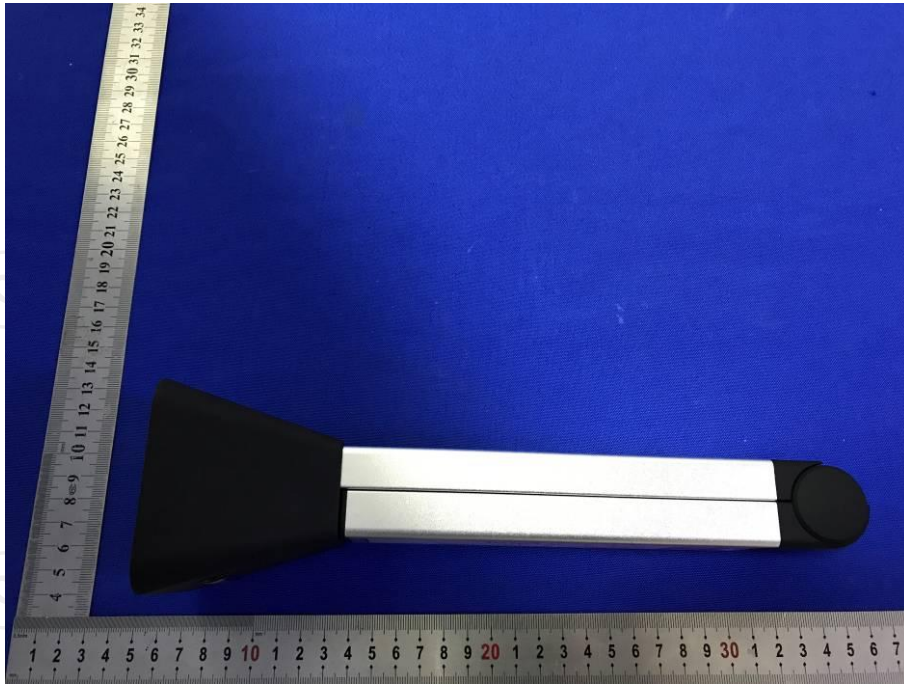

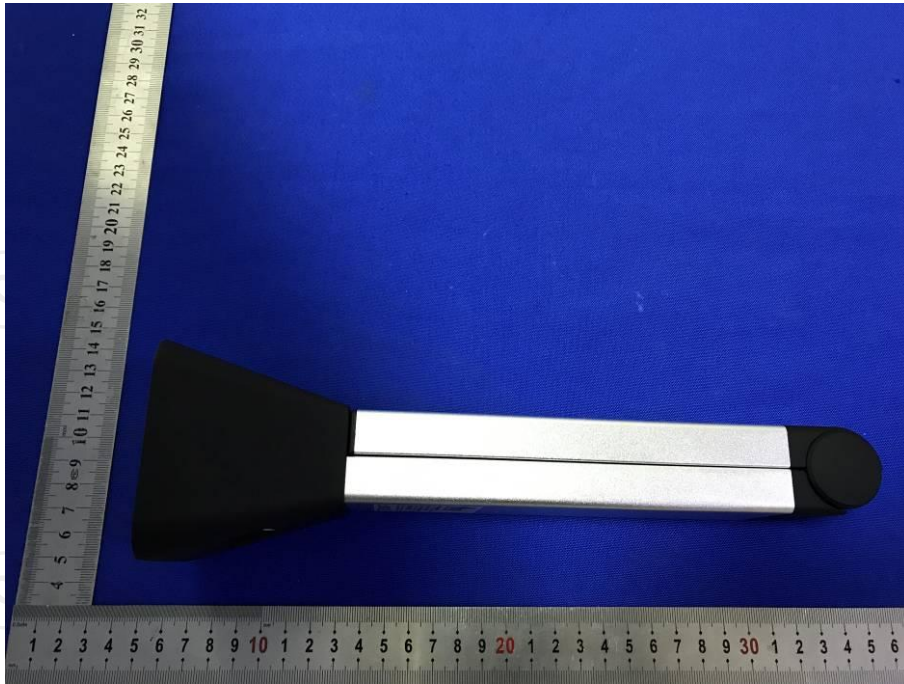



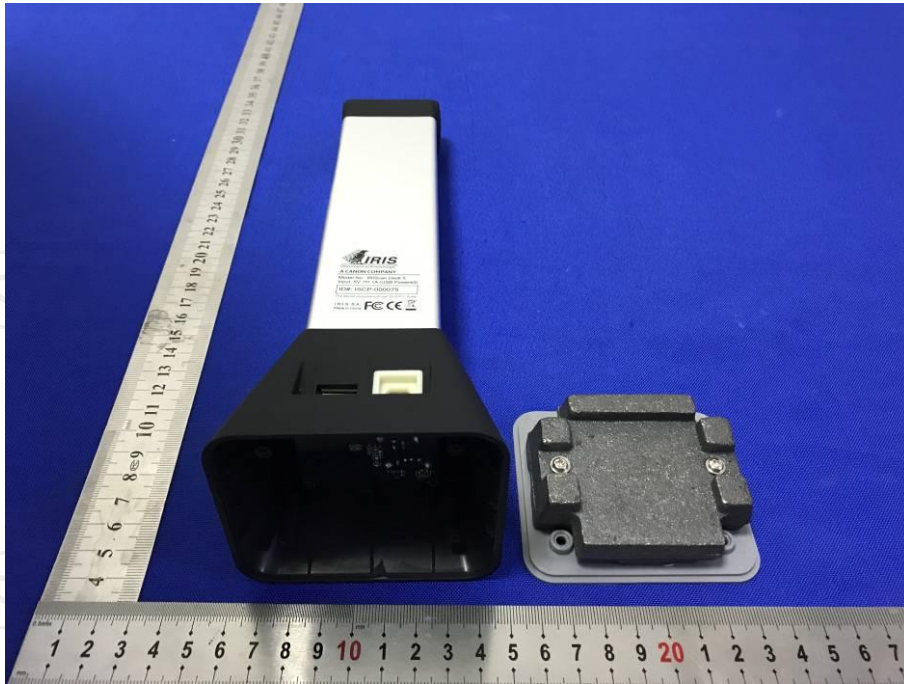

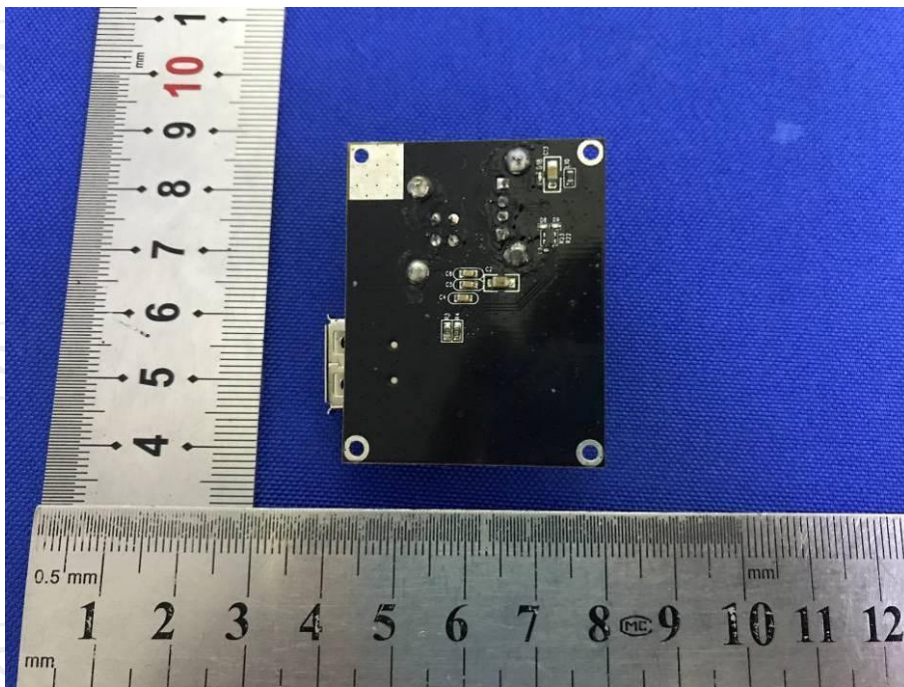
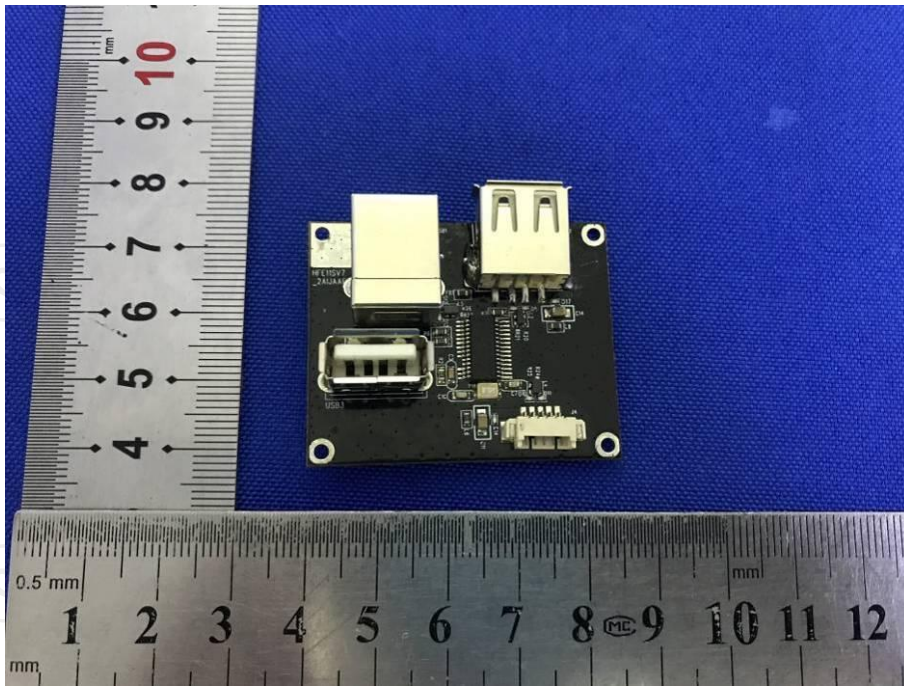

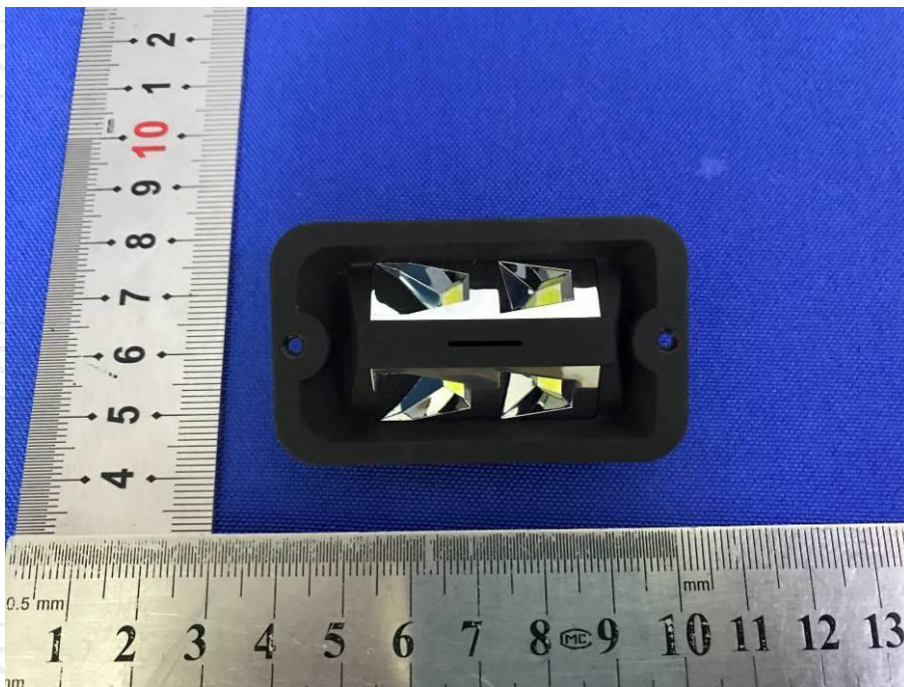
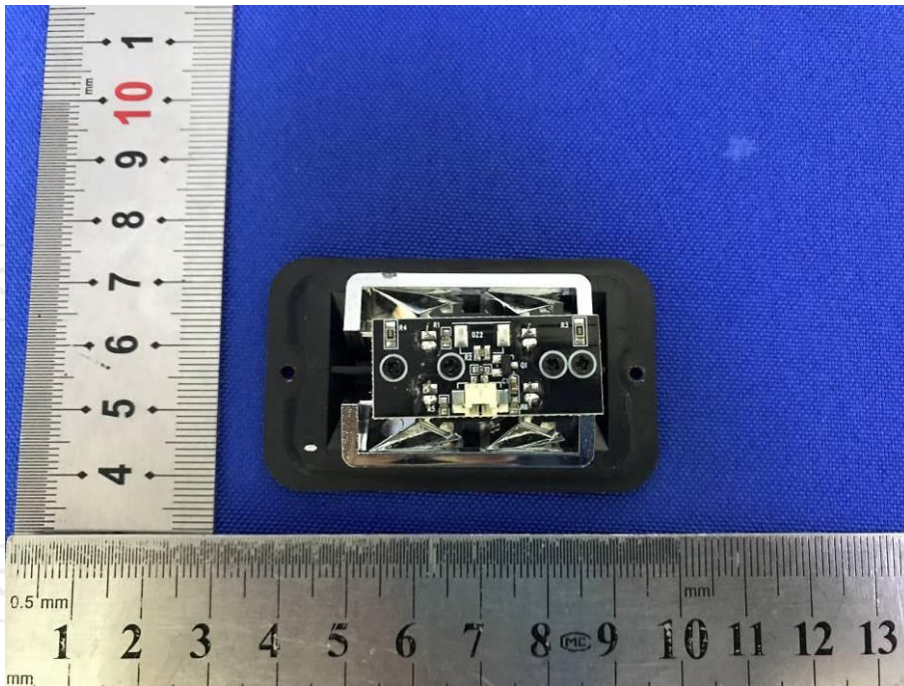

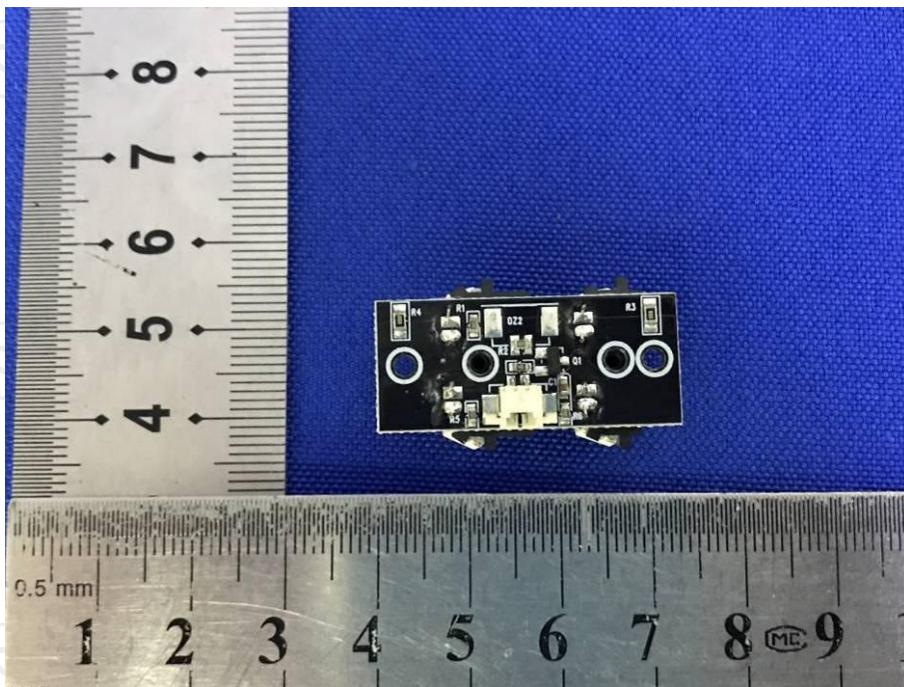
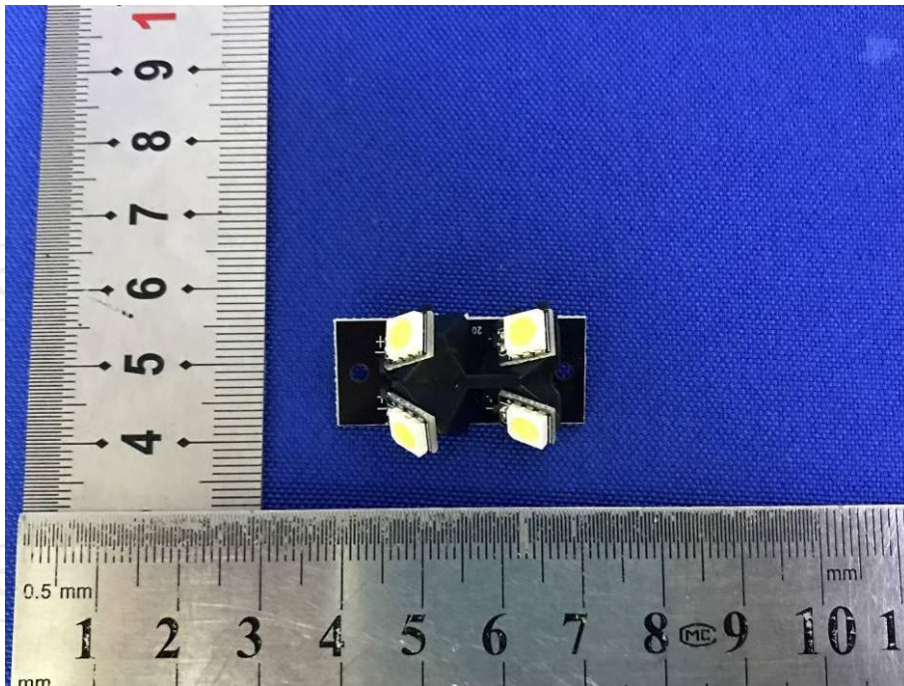

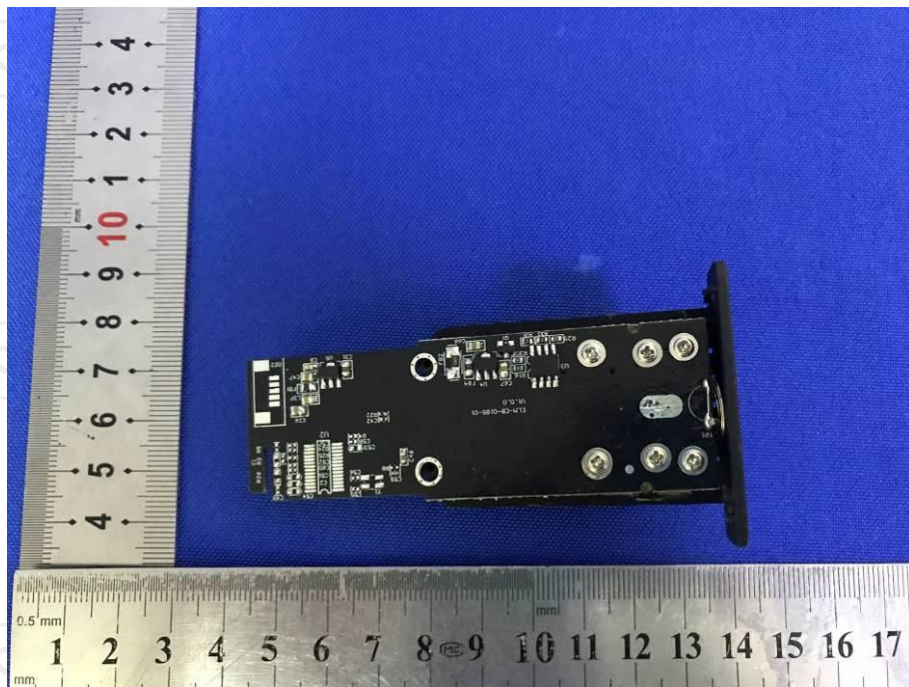
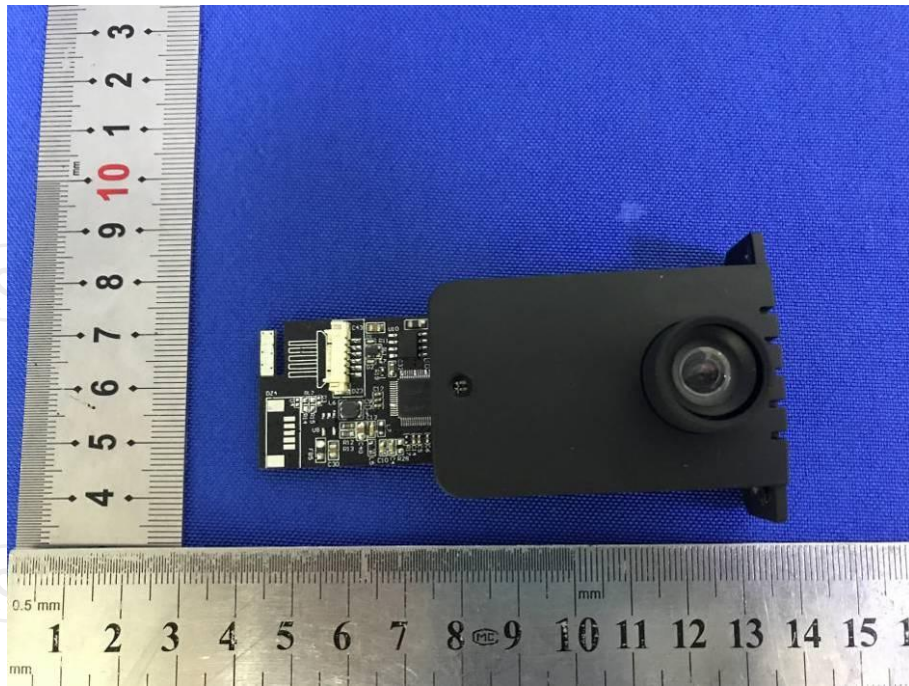

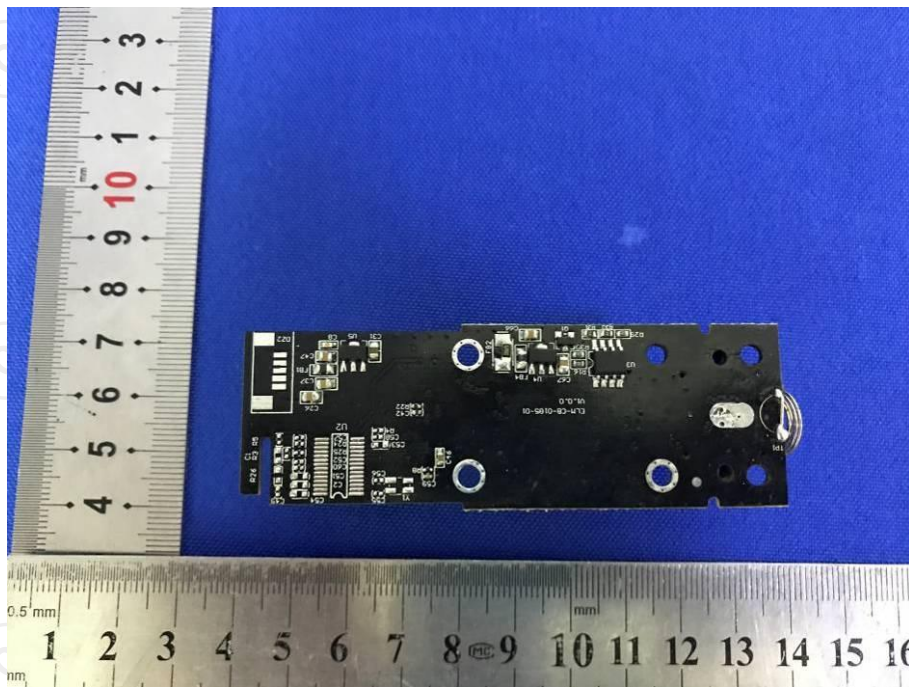
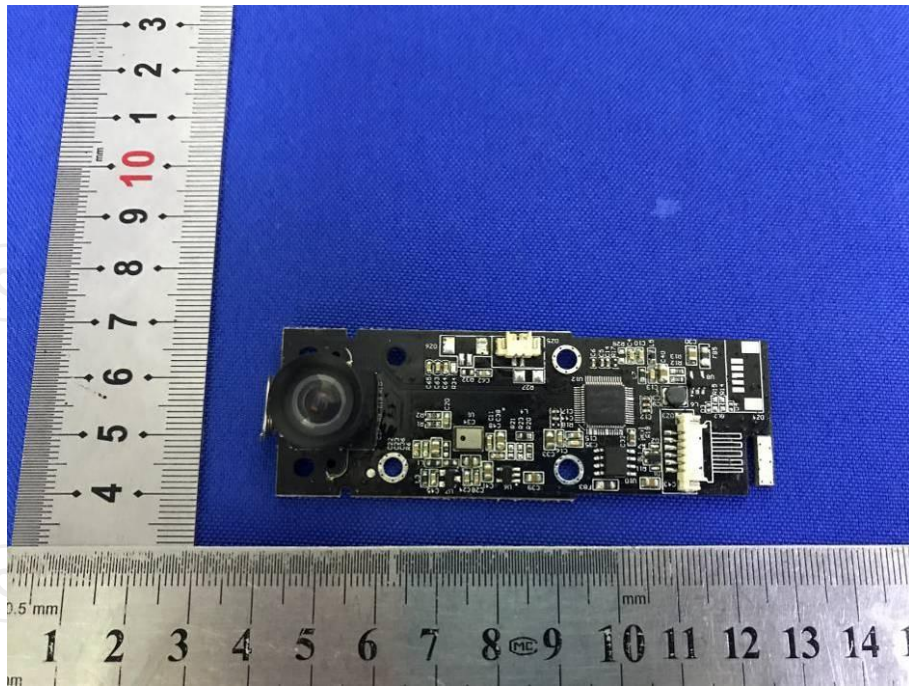

*******END OF REPORT*******